

Reversing servo (steam engine reverse lever *or* waterjet thrust bucket)
Has only two positions, as shown in diagrams below

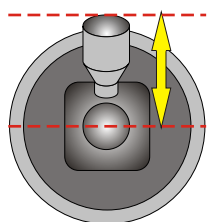

Throttle stick
forward

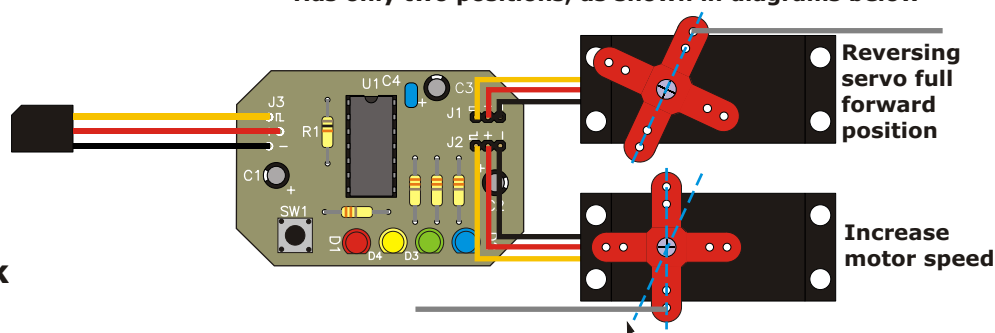

Steam regulator servo or electronic speed controller
Moves proportionally with throttle stick

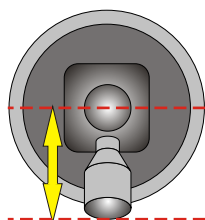

Throttle stick
back

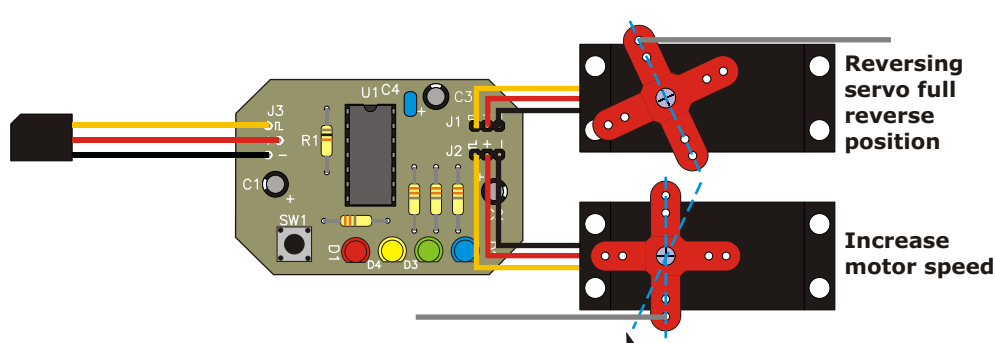

P105 is a microprocessor-based unit which connects to the throttle channel of your radio. It has two outputs for controlling either a model steam engine steam regulator and reversing valves via two servos, or an electrically driven water-jet via a speed controller and a reversing bucket servo.

Open the throttle slightly in either direction and the reversing servo 'snaps' instantly from one end of its travel to the other, to operate either the reversing valve lever of a steam engine or the reverse-thrust bucket of a water-jet. At the same time the engine speed will increase gradually with the stick movement, irrespective of whether forward or reverse has been selected. This makes the model as easy to operate as a conventional forward-and reverse electrically powered model - push the stick for forward and pull it back for reverse. **You don't need a third channel to change the model's direction from ahead to astern.**

P105 can be used with a second servo instead of an ESC to control the throttle of a model with a water-jet powered by an I/C engine. You can also use it to operate brushless electronic speed controllers. We strongly recommend that you fit a spring return lever to the throttle stick of your radio. This makes it very easy to find the "stop" position - you just let go of the stick. We do NOT recommend a ratchet-type stick mechanism because, of course, the stick needs to be at its centre position simply so that you can signal "reverse" to the P105 by pulling back on the stick. Case size 53mm x 37mm x 23mm (approx).

Installation

The unit is supplied with an ABS plastic box. File slots along the top edge of the base (the deeper of the two parts) to allow the leads to exit the case; make sure that the lid does not trap or squeeze the leads when fitted. Don't try to glue or stick the unit to the inside of case; it won't come to any harm loose inside the box. Mount the box to the inside of the model in a suitable position, avoiding long extension leads and making sure it is clear of the bottom of the hull in case of water ingress. We use self-adhesive Velcro "dots" for this job - see ACTION lists. Don't forget to program the P105 *before* you seal it into its box!

DO NOT USE A 6V SEALED LEAD ACID OR 5-CELL RECHARGEABLE PACK TO POWER THE RECEIVER DIRECTLY. When fully charged it can exceed the terminal voltage of the microprocessor. A receiver which is powered by a 4-cell pack or via a BEC regulator is fine, however.

How to program the P105

(Follow the instructions in this section in conjunction with the diagrams on pages 3 and 4).

Before using the P105 you will need to set the positions for the reversing servo for forward and reverse operation. You'll also need to set the limits for throttle, depending on the type of throttle control being used (ESC or servo).

These instructions assume that the P105 is correctly connected to the receiver and throttle control. Before starting the programming process be sure that you can easily see the four indicator LEDs and can press the button on the P105.

For normal operation power up the transmitter and receiver. The red LED on P105 will illuminate while the unit is waiting for a valid signal from the receiver and autsetting its neutral position to correspond with the Tx throttle stick. When the red LED clears and the yellow LED turns on, you have less than 1 second to press the button on P105 to enter programming mode.

To start the programming process, press and hold the button while the red LED is on and wait until the yellow LED has been on for at least two seconds before releasing the button. If the P105 has entered programming mode the red LED will light.

Moving the throttle stick now will cause the reversing servo to move. Adjust the throttle stick until the reversing servo is in the required 'reverse' position and press the button. The reverse position will be stored; the red LED will go out and the yellow LED will light.

Adjust the throttle stick until the reverser servo is in the required position for forward drive and press the button. The yellow LED will clear and the green LED will light up.

The throttle stick now operates the steam regulator valve servo or electronic speed controller, depending on the installation. *There are separate diagrams for each type of installation on page 4.* Adjust the stick to get the minimum engine speed (stop); with a reversing speed controller this will be with the stick centred. When the minimum speed position has been found press the button. The green LED will go out and the blue LED will light up.

Adjust the throttle stick to give the desired maximum motor speed (note - this does not have to be the maximum movement of the steam regulator or the fastest motor speed the ESC can deliver). When this setting has been achieved press the button for the last time. The setting is stored and the unit will enter normal Operation Mode; this is indicated by a red LED if forward throttle is selected or green for reverse.

Recovery Service

A recovery or repairs service ensures that you will not be left with a dead unit for any reason. The Service Charge for this kit is £13.00 including parts (including return shipping cost IN UK).

All returns should include full Credit Card details (Name & Address of cardholder, Card Number, Expiry Date and Card Security Number)

ACTION R/C ELECTRONICS, 1 Llwyn Bleddyn, Llanllechid, Bangor LL57 3EF, United Kingdom

The small print.....

ACTION R/C Electronics guarantee all products to be free from manufacturing defects for 12 months from date of purchase. This does not cover suitability for specific applications; components worn or damaged by use, tampering or incorrect connection; alteration to original components; damage to batteries or other equipment through use; misuse, or shipping damage. Where goods are found to be faulty, the customer shall return them to ACTION R/C Electronics in their original condition and with their original instructions, packaging etc. Our liability is limited to repairing or replacing goods to their original specification and will not exceed the cost of the goods. By using the product the user accepts all liability. Where a fixed repair charge is applicable, ACTION R/C Electronics shall undertake repairs to the extent that they are judged economically viable. Where such is not the case then the customer will be offered the option of crediting the repair charge towards the cost of a new unit or having the faulty unit returned and the charge refunded (less the cost of return carriage). We reserve the right to modify this guarantee without notice.

Note- Servos/speed controller must be connected as shown i.e. With black (-ve) wire nearest edge of circuit board

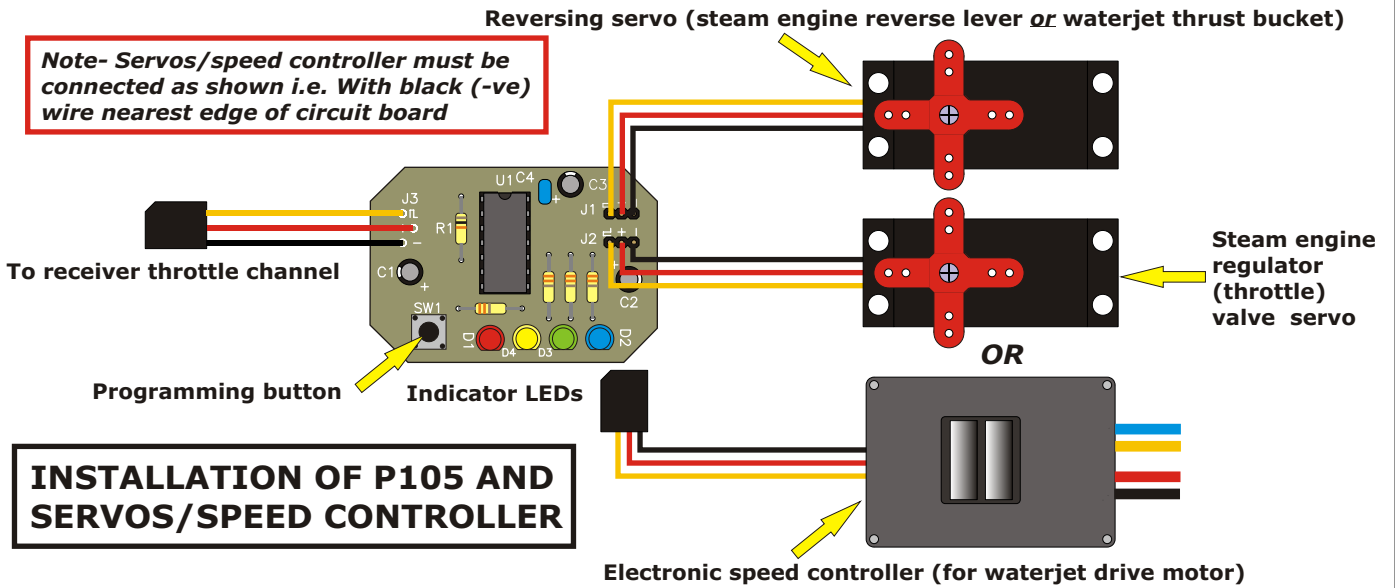

INSTALLATION OF P105 AND SERVO/SPEED CONTROLLER

INITIAL SET-UP; PROGRAMMING MODE

Turn on Tx > turn on Rx > RED LED lights. Press button within 1 second and hold until yellow LED has been on for 2 seconds > Release button > RED LED lights > P105 is now in Programming Mode

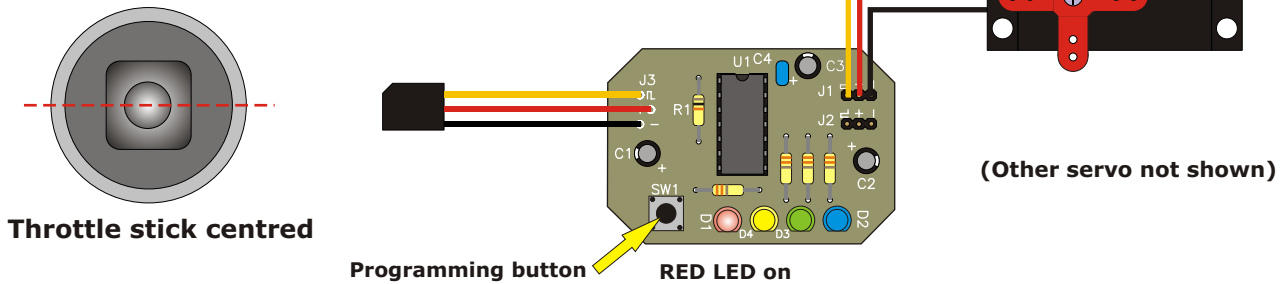

INITIAL SET-UP; PROGRAMMING REVERSING SERVO

Pull stick back until required reverse position of reversing servo is reached > Press button > YELLOW LED lights

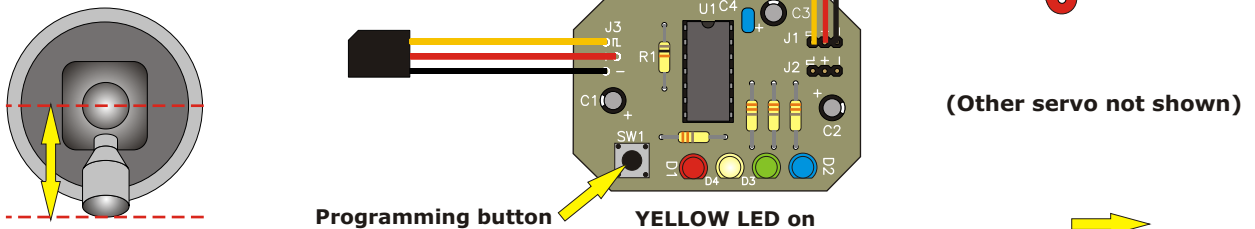

Push stick forward until required forward position of reversing servo is reached > Press button > GREEN LED lights

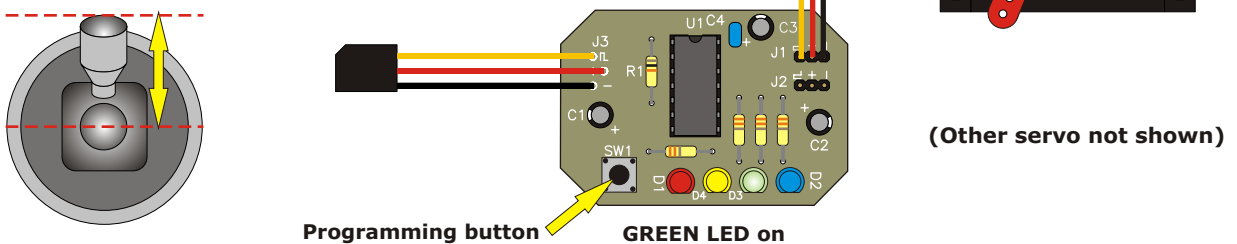

Steam engine application:

INITIAL SET-UP; PROGRAMMING STEAM REGULATOR VALVE SERVO

Pull stick back until required 'minimum engine speed' position of regulator servo is reached > Press button > BLUE LED lights

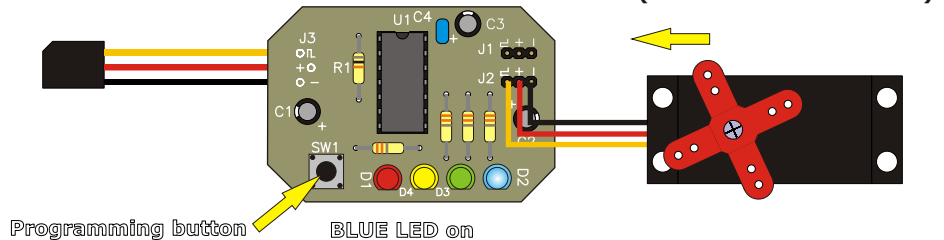
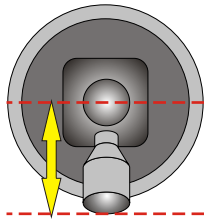

Push stick forward until required maximum throttle position of regulator servo is reached OR speed controller is at "full speed" > Press button > BLUE LED goes out and RED LED lights > Operating Mode

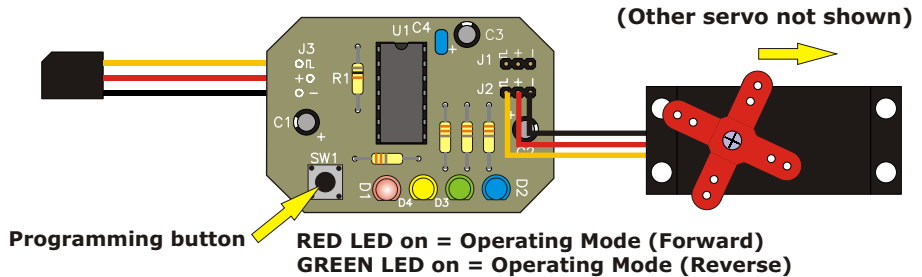
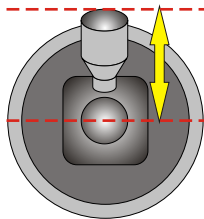

OR

Electric-powered waterjet

INITIAL SET-UP; PROGRAMMING ELECTRONIC SPEED CONTROLLER

Move stick until speed controller is at "motor stopped" position (i.e. *stick centred*) > Press button > BLUE LED lights

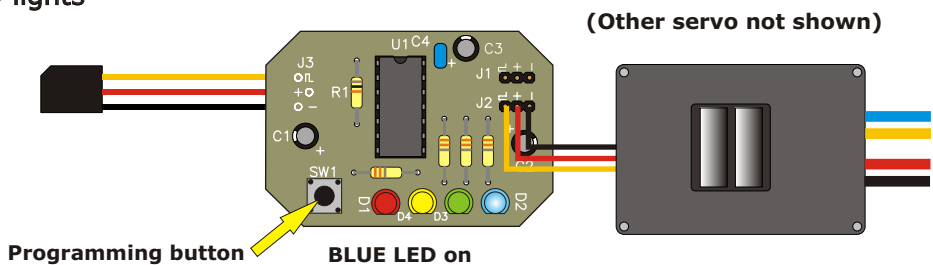
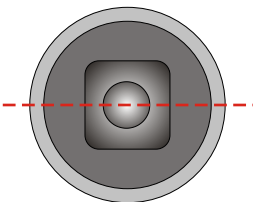

Move stick until speed controller is at "full motor speed" position (i.e. *stick forward*) > Press button > BLUE LED goes out and RED LED lights > Operating Mode

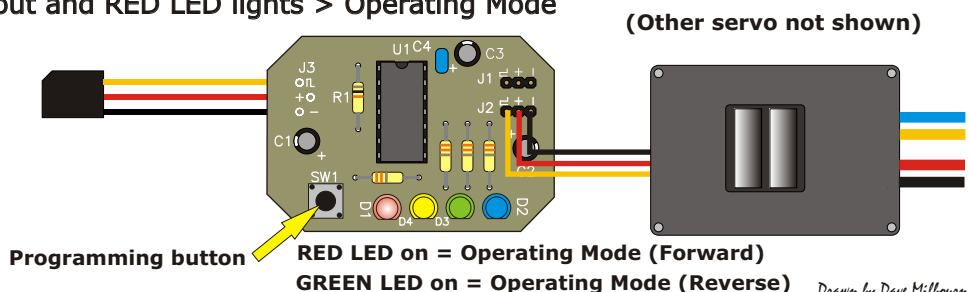
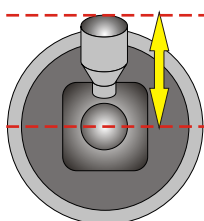

**P105
KIT**

COMPONENT LAYOUT

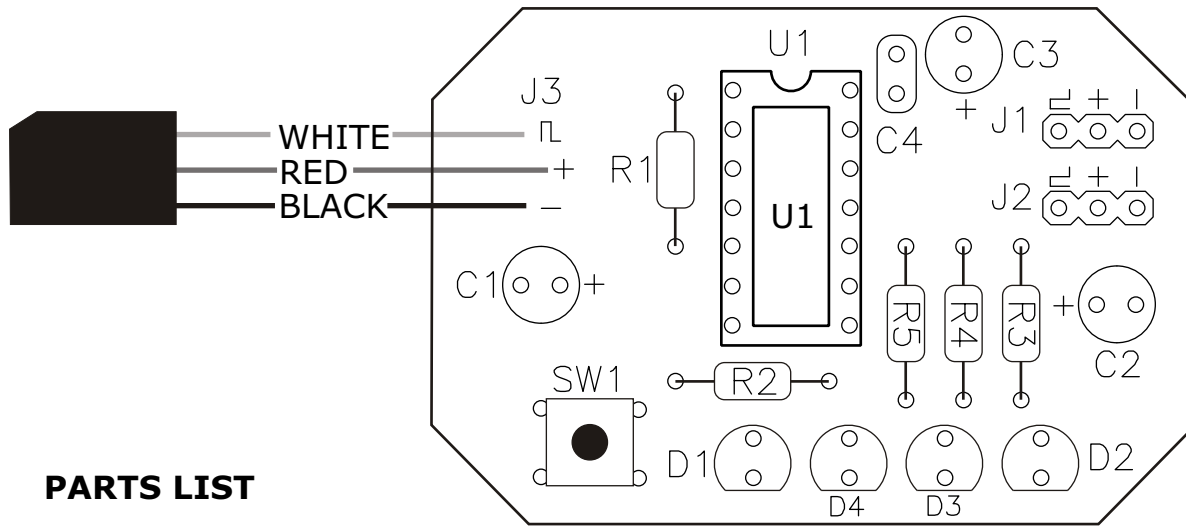

PARTS LIST

- D1** Red LED
- D2** Blue LED
- D3** Green LED
- D4** Yellow LED
- R1** 10K 1/4W resistor (BROWN/BLACK/ORANGE)
- R2-R5** 330R ----- do ----- (ORANGE/ORANGE/BROWN)
- C1-C3** 100uf x 6.3v electrolytic capacitors
- C4** 0.1uF mono capacitor
- SW1** Tactile switch
- U1** PIC16F684 microprocessor and 14-pin DIL socket
- J1-2** 3-pin gold plated headers
- J3** Futaba type Rx lead and plug
- PCB** P105
- Case** Rx 2008 with screws and label

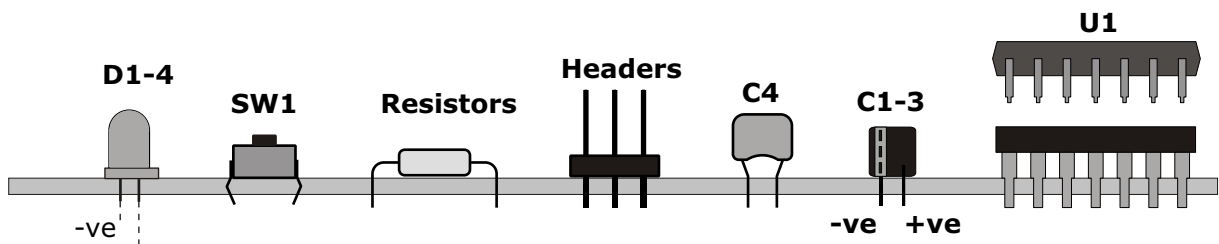

COMPONENT MOUNTING DETAILS

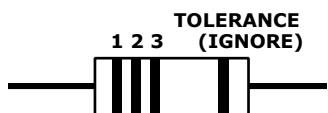

RESISTOR COLOUR BANDS

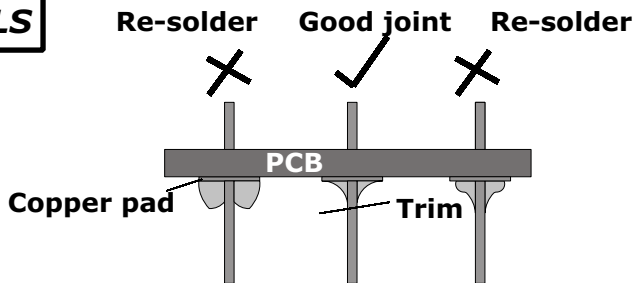

SOLDERING TIPS

P105 KIT INSTRUCTIONS

PCB

The Printed Circuit Board has an insulated (Component Side) and a tinned track side. Components are mounted on the insulated side and soldered on the track side. The PCB for this Project is fully prepared and requires no additional work. Look carefully at the area of the PCB you are working on when soldering to ensure that you do not apply an extra connection with a splash of solder

TOOLS

For construction you will require a soldering iron with a fine pointed bit and flux core solder (22 SWG recommended) a small pair of wire cutters, a screwdriver to make connections and, of course, a good level of light.

PARTS - DO NOT HANDLE ITEMS IN BLACK CONDUCTIVE FOAM UNTIL INSTRUCTED. (MOS DEVICES)

1/ The short bars with colour bands and a wire at each end are resistors R - R5. The coloured bands denote their values indicated on the drawing. Four are the same (330R) and one is different (10K) They can be mounted either way around, close to the PCB as drawn.

2/ The tubular electrolytic capacitors C1-C3 are marked with the value 100uF and the working voltage they also have a band down one side of the plastic sleeve with a (-) Negative sign on it which signifies which leg goes to the negative. The opposite leg of the capacitor, of course, goes to the positive and is the longer of the two legs Capacitor polarisation (+ and -) is clearly shown on the drawing; the negative bands on all these capacitors face outwards from the centre of the board.

3/ The small blue component with two wires is multi-layer 0.1uF capacitor C4 (marked 104). It can be fitted either way round.

4/ The 4-legged component with a square body and a button on the top is tactile switch SW1. Note that it has a definite "click" when pushed down. It will only fit into the PCB one way around. It should be fitted by inserting the ends of each leg into the PCB and gently rocking the switch body from side to side while applying downward pressure to push the legs into the holes.

5/ The 14-pin integrated circuit U1 is marked with its type code PIC16F684; see the drawing together with the Parts List. It is delivered in conductive foam and should be left in the foam until you are about to fit it. Being a MOS device (Metal Oxide Semiconductor), it can be damaged by static electricity and care must be exercised when handling. It is supplied with a socket. This will enable the builder to solder in the socket during construction, then fit the IC at the end of construction.

6/ The three-pin mouldings with long gold plated pins one side and shorter extensions the other side are known as headers. The short-pin end goes through the PCB for soldering, leaving the long pin ends sticking up. These are the pins to which you will fit the link and the connecting plug leads

7/ The four LEDs (Light Emitting Diodes) are soldered as shown. Note that the order D1 to D4 is NOT consecutive along the board (it goes D1, D4, D3, D2). The printed legend on the board and the Parts List indicate which colour goes where. Note that the base of each diode has a flat on it; this corresponds to the negative lead (which is the shorter of the two) and should be fitted nearest the edge of the board.

CONSTRUCTION

As few parts are used in the construction of the receiver, full construction notes are not needed, just a few pointers. A full pictorial sequence of the build is shown on our website www.action-electronics.co.uk if you follow the links to P105 and then click on the small graphic or the "Further Info" button.

Use pointed, selflocking tweezers to hold the headers in place against the PCB while soldering one pin, then remove the tweezers and solder the other two pins.

The receiver lead goes into holes J3. MAKE SURE YOU FIT THIS WITH THE WIRES THE CORRECT WAY AROUND!! Strip about 6mm of insulation from each wire, twist the strands together and apply a light tinning of solder. Snip the end at about 45 degrees and it should fit into the PCB hole. Trim off surplus as shown in Soldering Tips.

NOTES ON MOS DEVICE HANDLING - USE A SHEET OF ALUMINIUM, COOKING METAL FOIL WILL DO.

Place it on the work surface. Place the PCB, solder side down on it. Place the black conductive foam on it and then rest your hands on it, holding them there while you read through the part of the instructions. The PCB, any tools, the PIC chip and you are now all at the same potential, i.e. static neutralised.

WARNING - DO NOT use the black foam as a packing foam in the finished unit, it is CONDUCTIVE.

The rear of the board can now be cleaned with something like an old toothbrush and some spirit cleaner. Meths will do but Isopropyl Alcohol is very much better. Then check all over the soldered side of the board for good joints and no solder bridges between tracks or round pads. That's the PCB construction completed

CASE

File a small slot at one end, along the top of the of the case base, to allow the receiver lead to exit without being squashed or trapped when the lid is screwed down. A small cutaway will be necessary in the lid to allow you to fit the two servo leads onto the header pins. This is shown in the photo sequence on the website. Installation is a matter of choice but we suggest self-adhesive Velcro "dots" to hold the box in place in the model. See ACTION lists for price.

P105 SINGLE STICK REVERSER

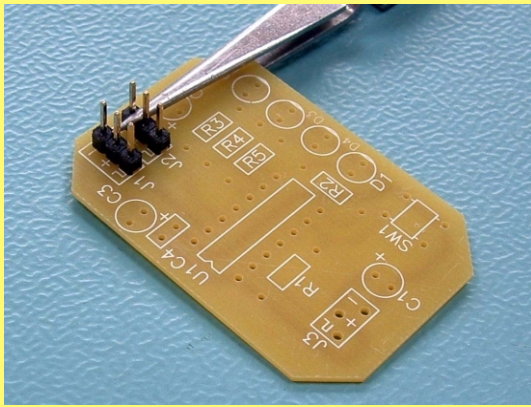

PICTURE 1: PCB with headers

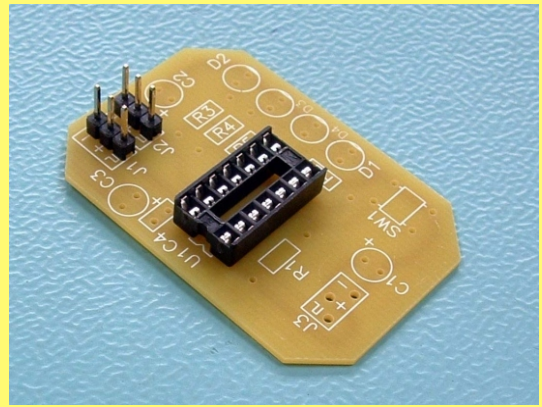

PICTURE 2: Add I/C socket

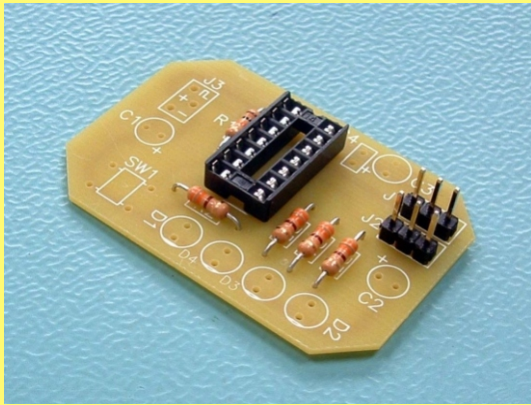

PICTURE 3: Resistors added

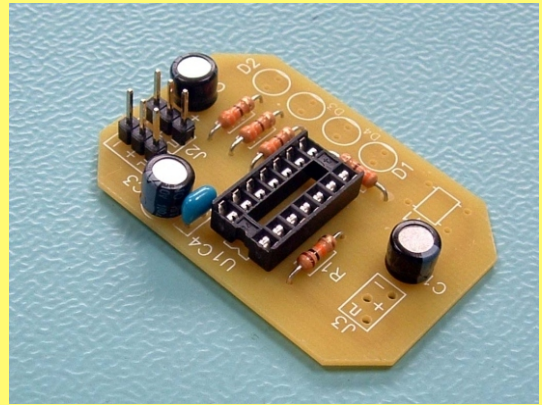

PICTURE 4: Fit capacitors



PICTURE 5: Add tactile switch (button)



PICTURE 6: Fit 4 x LEDs as shown



PICTURE 7: Fit lead and PIC chip. NOTE! ANTI-STATIC PRECAUTIONS REQUIRED



PICTURE 7: Finished unit