

P40D

MARINE MOTOR MIXER For 2-3 motors



This on-board marine motor mixer will suit models with two or three electronic speed-controlled motors. It now has four user-selectable 'degrees' of mix which make it suitable for models from fast launches to very manoeuvrable work-boats such as tugs. This offers full proportional control of motors and steering from only two radio channels, although it will work with sets of four or more channels. It has proved to be compatible with most electronic speed controllers equipped with full forward and reverse power function, *including those for brushless motors*. Use of BEC is not recommended but can be accommodated. We strongly recommend the use of a separate battery pack for each motor to avoid the complications due to earth loops which can arise with resetting microprocessors.

Straight-through output pin connections are provided for a rudder servo and a third, unmixed speed controller for a central motor. This eliminates the need for Y-leads. Full installation, setting-up and operating instructions are supplied.

Minimum input pulse length	0.9ms
Maximum input pulse length	2,1ms
Neutral (centre stick)	Autoset (takes 2 seconds)
Receiver voltage	4.8v - 6v*
Case size	55 mm x 36mm x 20mm
Power ON indicator	LED
Adjustments	Four different degrees of motor mix via 2-way PCB switch

*DO NOT USE EITHER A 5-CELL RECHARGEABLE PACK OR A 6V LEAD-ACID BATTERY FOR POWERING THE RECEIVER *DIRECTLY*
Power fed from a regulated supply e.g. a Battery Eliminator Circuit is fine.

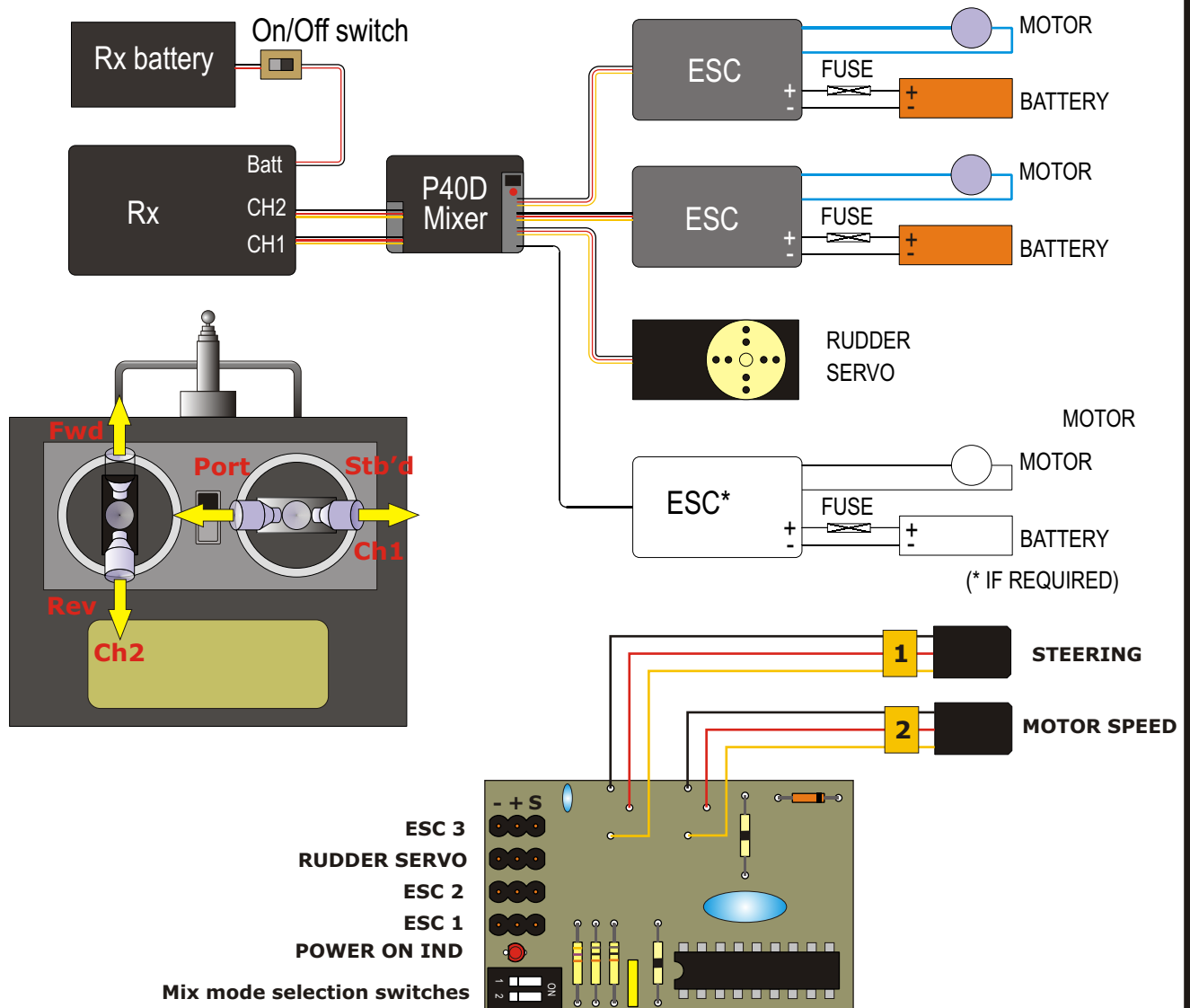

P40D

MARINE MOTOR MIXER

For 2-3 motors



This on-board marine motor mixer will suit models with two or three electronic speed-controlled motors. It now has four user-selectable 'degrees' of mix which make it suitable for models from fast launches to very manoeuvrable work-boats such as tugs. This offers full proportional control of motors and steering from only two radio channels, although it will work with sets of four or more channels. It has proved to be compatible with most electronic speed controllers which are equipped with full forward and reverse power function, *including those for brushless motors*. Use of BEC is not recommended but can be accommodated. We strongly recommend the use of a separate battery pack for each motor to avoid the complications due to earth loops which can arise with resetting microprocessors.

Straight-through output pin connections are provided for a rudder servo and a third, unmixed speed controller for a central motor. This eliminates the need for Y-leads.

Neutral setting up (centre stick)

Receiver voltage

Case size

Power ON indicator

Adjustments

Autoset (takes 2 seconds)

4.8v - 6v*

55 mm x 36mm x 20mm

LED

Four different degrees of motor mix via 2-way PCB switch

DO NOT USE EITHER A 5-CELL RECHARGEABLE PACK OR A 6V LEAD-ACID BATTERY FOR POWERING THE RECEIVER *DIRECTLY

Power fed from a regulated supply e.g. a Battery Eliminator Circuit is fine.

OPERATION

Always switch on your Transmitter first, then your receiver. (Allow the two to 'bind' if you are using a 2.4GHz set). Wait for a further three or four seconds before moving either of the transmitter sticks; this allows the on-board microprocessor to set itself to the incoming neutral signals from the transmitter. When closing down, switch off the receiver first, followed by the transmitter.

DO NOT PLUG OR UNPLUG ANY CONNECTIONS TO THE RECEIVER OR MIXER WITH THE POWER SWITCHED ON. IT CAN FATALLY DAMAGE MICROPROCESSORS.

MODES OF OPERATION

P40D has four different degrees of mixing, depending on the type of model into which you have fitted it. These are set by moving the little switches 1 and 2 as follows:

Mode 1: SW1=ON; SW2=ON - This is designed for fast models such as patrol boats and modern lifeboats. The inner motor in a turn is reduced in speed by applying increasing amounts of rudder command but it will not go into reverse, irrespective of how fast the model is travelling. This avoids the model slowing down noticeably when a turn is applied.

Mode 2: SW1=OFF; SW2=ON - This allows the inner motor to go into reverse at full rudder but restricts that reverse speed to 25%. It suits slightly slower models than Mode 4 or where a little more manoeuvrability is required.

Mode 3: SW1=ON; SW2=OFF - As Mode 2 except that the inner motor can reverse up to 50% full speed at full rudder.

Mode 4: SW1=OFF; SW2=OFF - This is the classic "spin-on-the-spot" mode where the inner motor can be made to run at full reverse speed with full rudder and a little throttle. It is designed for very manoeuvrable models such as tugs.

Note that **NONE** of the modes allows the inner motor to reverse at full throttle and full rudder which would cause a drastic "lurch" in the model's progress at speed. Selection of the correct mode is down to the user by seeing what the model does when different throttle and rudder commands are given. If in doubt we suggest starting with Mode 1, which is the most "gentle" mix.

CONNECTION and TESTING

Connect the plugs on the two fitted leads marked **S** and **T** to the **S**teering and **T**hrottle outputs of your receiver. Connect the port and starboard speed controllers to Motor 1 and Motor 2 output pins, ensuring that the leads are fitted the right way around (See drawing). The third (central) motor speed controller can be connected if you are using a central motor. This will follow the throttle control *only* and will not be affected by any mixing. The last connection is the steering servo. **IF YOU ARE USING ACTION SPEED CONTROLLERS THEN YOU SHOULD FIT A SEPARATE BATTERY FOR EACH MOTOR** to avoid the possibility of ground loops which could cause loss of motor control.



SETTING UP YOUR MIXER

Please follow these instructions in exactly the order in which they are written, referring to the Setting Up diagrams. Remember that this unit is actually a small computer and that there is a regime involved in its operation. Ignore this and you'll quickly become frustrated!

The setting up directions assume a few basics:

- 1) Your transmitter has servo-reverse facility on both the motor and steering channels;
- 2) The motor control is on the LH stick of the transmitter while the steering is on the RH stick;
- 3) You have two spare servos to act as guides while you set things up (don't worry if you don't, but you'll then have to connect the mixer straight to the ESCs and motors for setting up); and
- 4) Your model has the conventional outward-turning props when viewed from behind the model i.e. Starboard=Clockwise and Port=Anticlockwise. If your model had inward turning motors then set up the system exactly as drawn and, when finished, simply reverse the two wires between each motor and its speed controller so that the motors now run in the opposite direction - easy!

Plug the mixer into the receiver; connect the steering servo to the mixer steering output and switch on. Check that the servo moves in the right direction on given command to steer the model with the rudder(s). If necessary, use the reverse switch on the transmitter to change the direction of the servo. Leave this switch alone for the rest of the set-up procedure.

Plug a spare servo into each of the mixer's ESC outputs (motors 1 and 2) and switch on. *Allow four seconds for the Autaset function to activate before moving any sticks on the transmitter.* Move the throttle and rudder sticks and check that the servo discs move as in the first three rows of the diagram. You may need to use the servo reverse switch on the transmitter throttle channel. Now try the commands in the last four rows of the diagram. You should need only to adjust only the position of the servos on the bench at this stage (i.e. swap over port and starboard) to effect the necessary changes. When you are happy with the results make a note of the position of the reverse switches on the transmitter for future reference.

Now disconnect the servos and install the mixer in the model. Connect the Port and Starboard speed controllers to the corresponding mixer output pins (Motors 1 and 2 - as dictated by the test servos). Connect the motors to the speed controllers and the speed controllers to the main drive batteries. NB if you are using BEC-equipped speed controllers then you **MUST** disable the BEC in all but one of them by removing the Red wire from the black plug which fits into the mixer. If you are using a separate battery for the recommended) then you must disable the BEC in ALL of the speed controllers. Switch on the radio. Move the transmitter sticks and check that the props turn in the correct direction as per the last column on the diagram. If either of the motors runs the wrong way then simply reverse its connection to the speed controller. (Brushless motors have three wires to the ESC; swap over any two of these wires to reverse the motor direction). **DON'T REVERSE THE CONNECTIONS FROM THE BATTERIES TO THE SPEED CONTROLLERS** unless you're a fan of minor explosions and expensive, grey smoke..... Adjust the neutral and peak settings of your speed controllers as per the supplier's manual if necessary. ACTION Condor ESCs have full Autaset and will take care of any further setting up automatically each time you power up. Remember that you MUST ALWAYS wait four seconds after switching on before moving either of the transmitter sticks.

RECOVERY SERVICE

A recovery or repairs service ensures that you will not be left with a dead unit for any reason.

The Service Charge for this kit is £18.00 including parts (including return shipping cost IN UK).

All returns should include full Credit Card details (Name & Address of cardholder, Card Number, Expiry date and 3-digit Card Security Number)

ACTION R/C ELECTRONICS, 1 Llwyn Bleddyn, Llanllechid, Bangor LL57 3EF, United Kingdom

The small print.....

ACTION R/C Electronics guarantee all products to be free from manufacturing defects for 12 months from date of purchase. This does not cover suitability for specific applications; components worn or damaged by use, tampering or incorrect connection; alteration to original components; damage to batteries or other equipment through use; misuse, or shipping damage. Where goods are found to be faulty, the customer shall return them to ACTION R/C Electronics in their original condition and with their original instructions, packaging etc. Our liability is limited to repairing or replacing goods to their original specification and will not exceed the cost of the goods. By using the product the user accepts all liability. Where a fixed repair charge is applicable, ACTION R/C Electronics shall undertake repairs to the extent that they are judged economically viable. Where such is not the case then the customer will be offered the option of crediting the repair charge towards the cost of a new unit or having the faulty unit returned and the charge refunded (less the cost of return carriage). We reserve the right to modify this guarantee without notice.

CONNECTIONS TO P40D

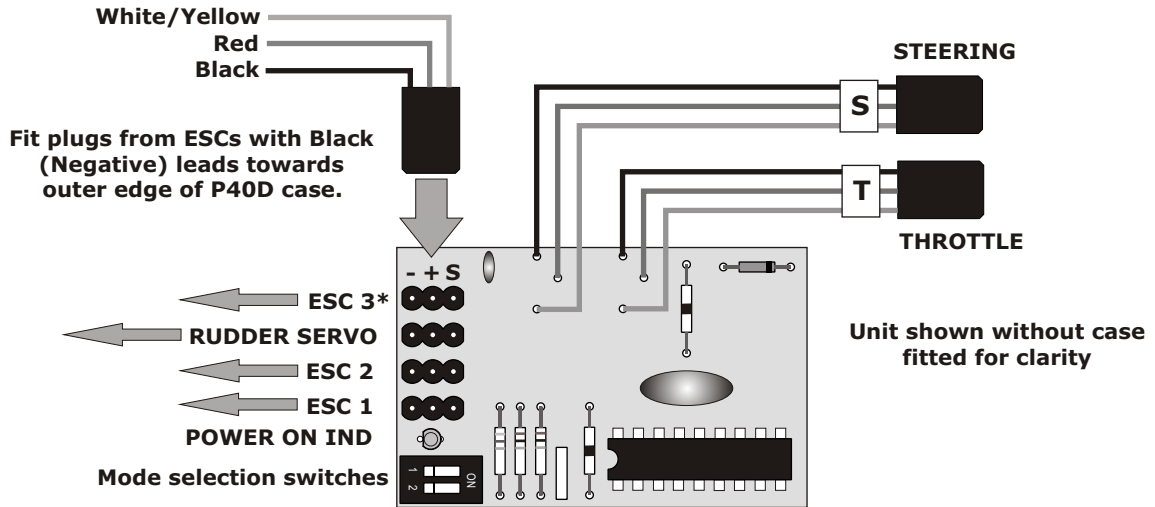

*IF REQUIRED

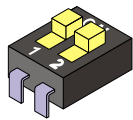

MODE 1

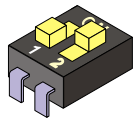

MODE 2

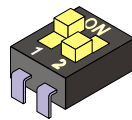

MODE 3

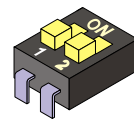

MODE 4

MODE SELECTION SWITCH POSITIONS

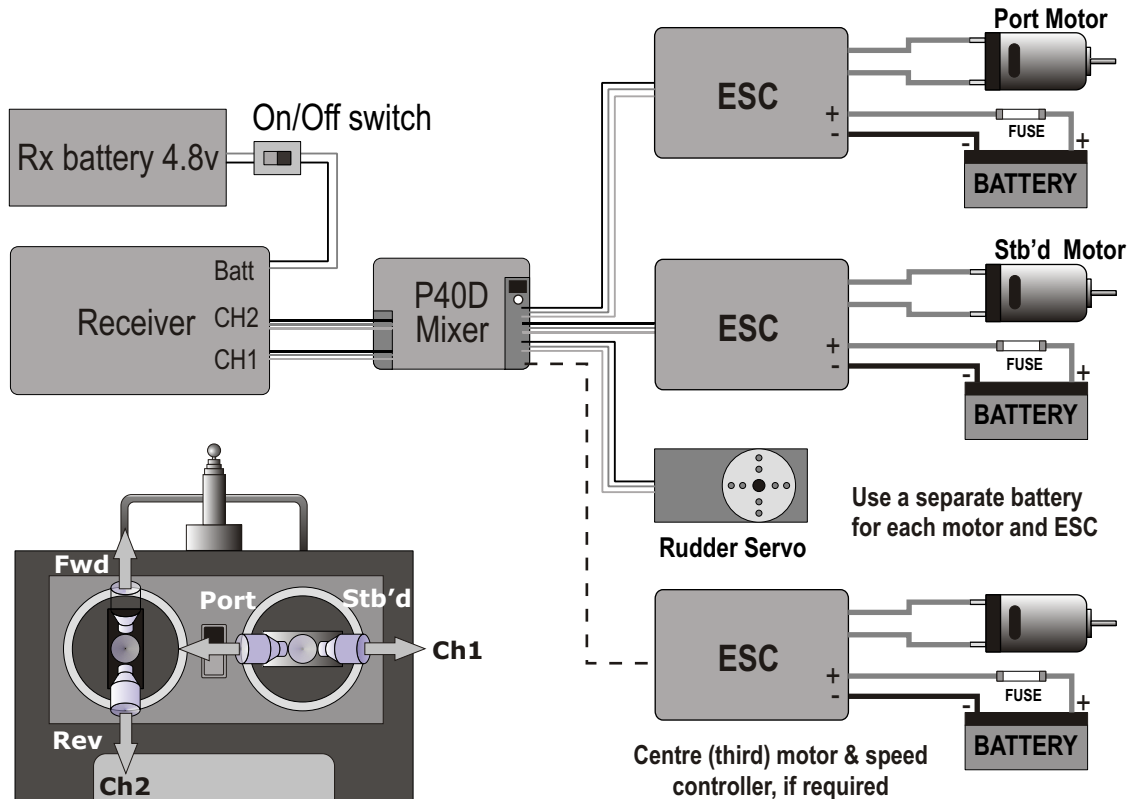







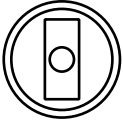
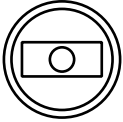
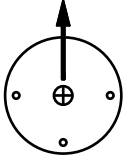
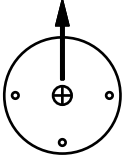
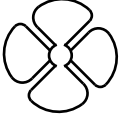
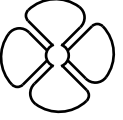
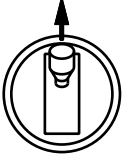
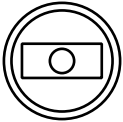
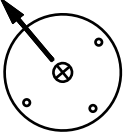
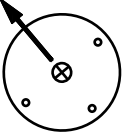

SYSTEM CONNECTIONS

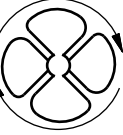
ACTION do not recommend the use of speed controllers fitted with Battery Elimination Circuitry. If you do use these then you MUST either disable the BEC in all but one of them or, preferably, disable it in all and use a separate 4-cell rechargeable pack for the receiver, as shown. BEC is disabled by removing the RED (Positive) wire from the ESC plug which fits into the receiver. If there is a slide switch fitted to the ESC then leave it ON or the ESC itself might not work.

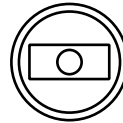
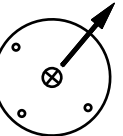
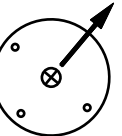
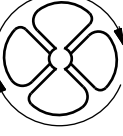
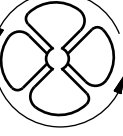
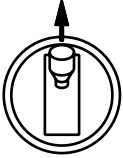
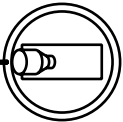
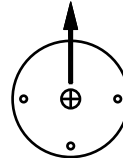
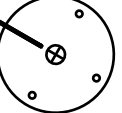
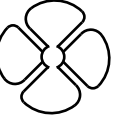
SETTING UP ACTION P40D MARINE MIXER USING TEST SERVOS

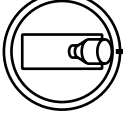
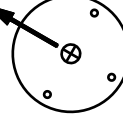
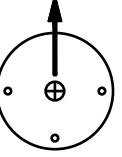
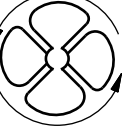
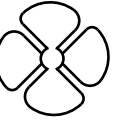
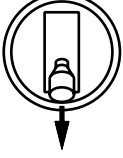
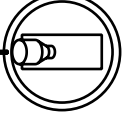
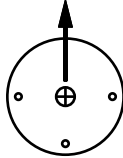
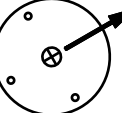
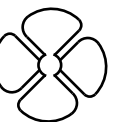
Set two on-board switches to ON and ON (Mode 1)

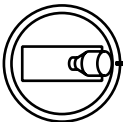
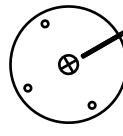
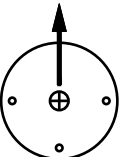
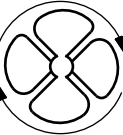
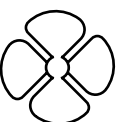
COMMAND	Tx stick positions		Test servo disc positions		Prop direction/speed	
	Motor	Steering	Port	Stbd	Port	Stbd
DEAD STOP + NO RUDDER					 STOP	 STOP
FULL AHEAD + NO RUDDER					 FWD	 FWD
FULL ASTERN + NO RUDDER					 REV	 REV
FULL AHEAD + HARD TO PORT					 STOP	 FWD
FULL AHEAD + HARD TO STBD					 FWD	 STOP
FULL ASTERN + HARD TO PORT					 STOP	 REV
FULL ASTERN + HARD TO STBD					 REV	 STOP



P40D MARINE MOTOR MIXER
Instructions for kit version

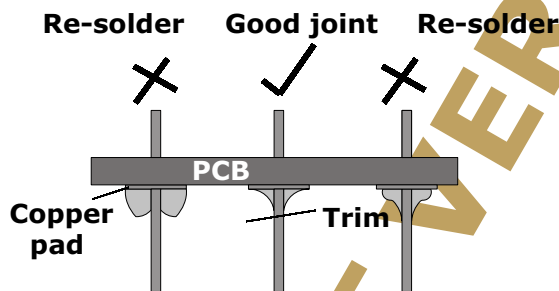
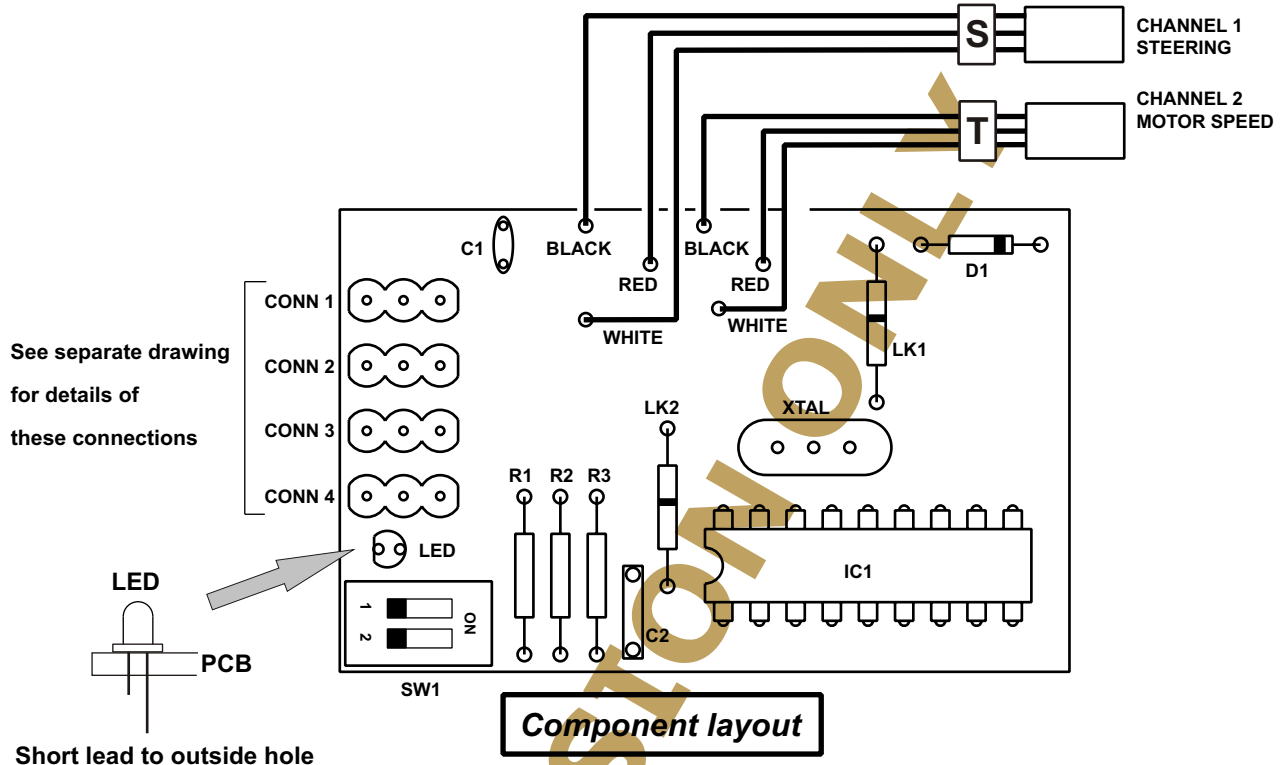

Soldering Tips



Resistor colour bands

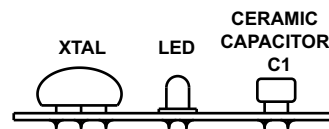

Component mounting details

Parts List

- | | |
|---------|--|
| IC1 | Programmed 18-pin PIC with PCB-mounted socket |
| XTAL | 4.0 MHz resonator (Blue with 3 pins) |
| D1 | 1N4148 Signal Diode (Small Orange glass component with coloured band at one end) |
| LED | 3mm Red or Green light-emitting diode |
| R1 | 470Ω 1/4W resistor (YELLOW/MAUVE/BROWN) |
| R2,3 | 10KΩ 1/4W resistors (BROWN/BLACK/ORANGE) |
| LK1,2 | Links (One central Black band) |
| C1 | 0.1uF Monolythic capacitor (Blue, marked 104) |
| C2 | 0.22uF Polyester capacitor (Square White, marked .22) |
| PCB | P40 printed circuit board |
| CONN1-4 | 3-pin gold-plated header connectors |
| SW1 | PCB-mounted 2-way DIL switch |
| Case | RX1000 type 41mm x 32mm x 20mm |
| Leads | 2 x Hitec/JR generic with alternative Futaba-type shells and cable markers |

P40D KIT INSTRUCTIONS

Warning - the 18 pin black moulded block must be left in the conductive black foam until it is required to be fitted. It is a MOS device and is sensitive to static electricity. You will be instructed in these notes how to fit it with no risk of damage. All kits have a tested and proved device supplied; any damaged devices will be charged for and will cost a substantial part of the kit price. The foam is conductive so do not use it as packing in a case with a powered-on circuit board.

TOOLS

For construction you will require a soldering iron (anything between 15 to 30 watts with a thin pointed bit) and flux cored solder (22 swg recommended). A small pair of wire cutters to trim wires covers all the tool requirements plus, of course, a good level of lighting.

PCB

The PCB for this project is made from the finest glass fibre material and is fully prepared. It requires no further work.

PARTS

- The PCB has an insulated (component side) and a tinned track side. Components are mounted on the insulated side and soldered on the track side.
 - The resistors are the two-wire items with coloured bands. The colour codes are read with reference to the parts list and Resistor Colour Bands diagram. The body colours may vary according to their manufacturer. The layout drawing shows the mounting positions.
 - The tiny glass component with two wires and a dark bar at one end is diode D1. Take note of the band when fitting it.
 - The 18-pin integrated circuit IC1 is a microcontroller known as a PIC. It will eventually mount into the 18-pin socket provided. Fitting the IC is normally the last operation in construction to avoid unnecessary handling. Both the IC and its socket have a small notch at one end; this is an orientation mark. The socket must be fitted with the notch as per the Component Layout. When the IC is fitted with its notch in the same direction it will be the right way round.
 - The crystal is a blue ceramic miniature component with three pins; it can be fitted either way round. It contains a frequency stable 4 MHz ceramic crystal element and two capacitors.
 - LK1 and LK2 are actually zero ohm resistors, or links. Easy to identify because they have one black band around the middle.
 - The small, coated two-legged device marked 104 is a monolithic ceramic capacitor of 0.1 uf, C1.
 - The small, white square two-legged device marked .22 J 63 is a poly capacitor of 0.22 uf, C2.
 - The 3-pin gold-plated connector is known as a header; easy to identify. There are four in this kit.
 - The small red or green dome with two connection pins is a LED - a solid state bulb. Note that the flat moulded in it is a polarising mark.

CONSTRUCTION

The PCB has a plain insulated side which is where the components are mounted, and a side with soldered tracks which is where the components are soldered. The golden rule is read the instructions twice so that you only solder once. Construction of the PCB is very straight forward, the components being easy to fit in any order. For those who would prefer a set of instructions, the following order is recommended. "Soldering Tips" may help those with little soldering experience.

- The 18 pin IC socket can be the first item. Note that the notch moulded into it matches the notch position marked on the drawing. This is most important as incorrect fitting will cause the microcomputer to be fitted the wrong way round. This will damage the microcomputer; they are expensive. When you are sure that it is in the right position and it is the right way round, solder all pins carefully.
 - Fit the resistors, ensuring that the correct value goes into the right position with reference to the drawings plus the colour codes in the parts list. After soldering each resistor into its respective position, cut off the spare wires.
 - The small glass diode can now be fitted. Bend the leads and fit it as shown in the diagram, with the dark band towards the end of the PCB.
 - LK1 and LK2 can now be fitted and soldered in the same way as the resistors. After soldering, clip off the spare wire.
 - Fit capacitors C1 and C2, again cutting off the spare wires after soldering.
 - Fit and solder the three-legged resonator (Xtal) referring to the drawing for its position.
 - The three-legged headers can be fitted now. Ensure that the short pin end goes through the PCB for soldering, leaving the long pin ends sticking up. These are the pins to which you will eventually connect your ESC & steering servo leads.
 - Fit the LED, noting the flat on the moulding goes towards the switch SW1. The switch SW1 can also be fitted and soldered at this point.
 - Servo leads with plugs to suit your outfit should now be fitted with reference to the drawing. Ensure that you get these connections right as it can cause a lot of problems if you get it wrong.
 - IC1 is the last part to fit. Use a sheet of aluminium as an anti-static "bench" (cooking metal foil will do). Place it on the work surface. Place the PCB solder side down on it. Place the black conductive foam on it and rest your hands on it, holding them there while you read through this part of the instructions. The PCB, PIC microprocessor and you are now all at the same potential i.e. any static voltage difference is now neutralised. You can now remove IC1 from its foam and fit it into the pre-soldered socket, ensuring that the notch is in the same direction as the notch on the socket.
 - Now double-check that everything has been fitted correctly and that all joints are good. The back of the PCB can be cleaned off with the help of an old toothbrush or similar and spirit cleaner (meths or, better still, isopropyl alcohol if you can get it).
 - The case requires no cutting. Feed the servo leads through the small square hole at one end of the case top. The long slot at the other end is for the connectors led and switch to be fully accessible. The case bottom can be glued when you are quite happy with the units functionality (recessed side down). The case is moulded in ABS plastic and Plastic Weld or Mekpak are suitable adhesives for this.

Warning - remove the cut wires & aluminium sheet from the work area before testing!

P40 MARINE MOTOR MIXER

PHOTOGRAPHIC BUILD SEQUENCE FOR KIT VERSION

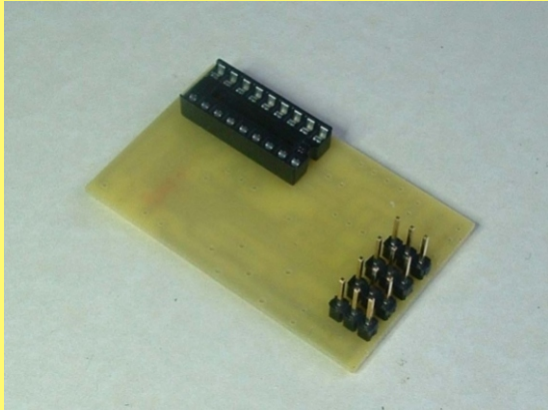

PICTURE 1: PCB with headers and I/C socket fitted

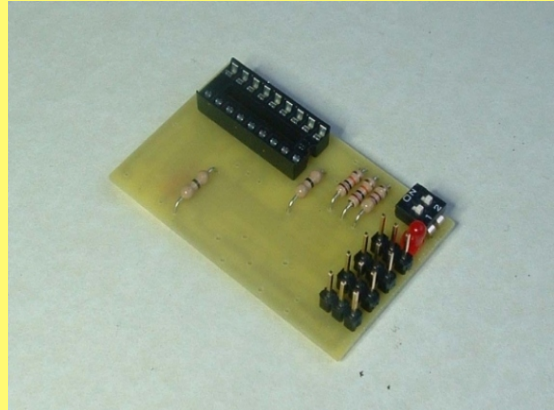

PICTURE 2: Resistors, LED & switch added

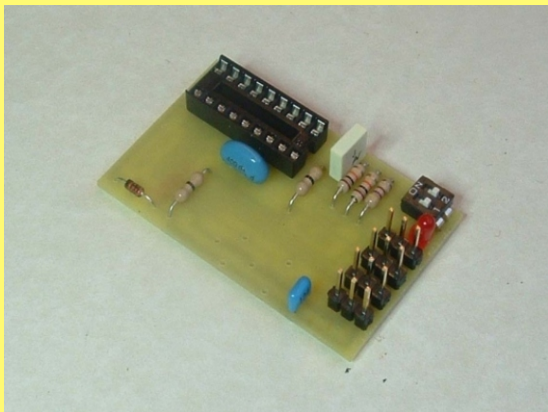

PICTURE 3: Capacitors, crystal and diode added

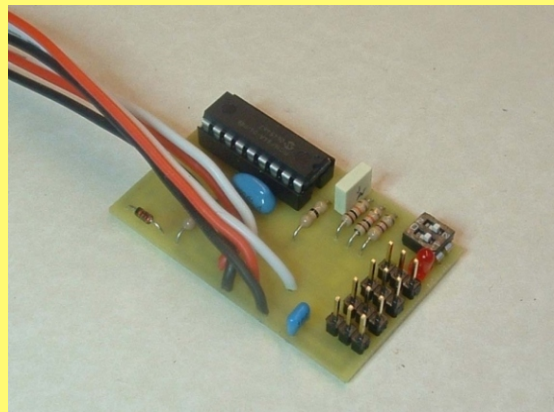

PICTURE 4: Fit leads and I/C. NOTE! ANTI-STATIC PRECAUTIONS REQUIRED

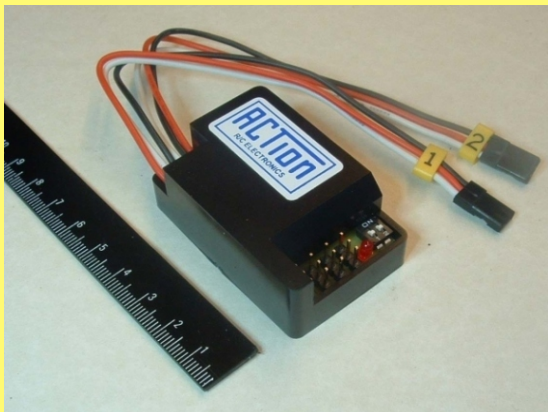

PICTURE 5: Finished unit in case, with sticker

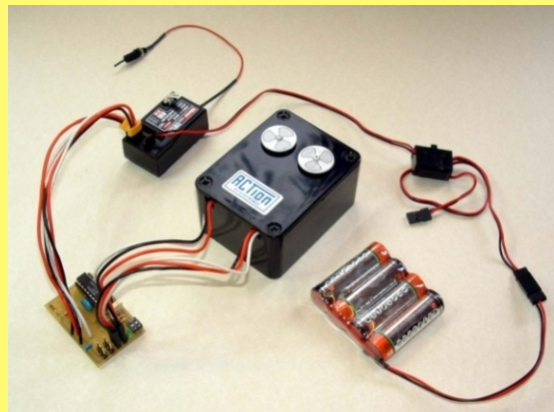

PICTURE 6: Testing a P40 prior to despatch



PICTURE 7: P40 and 3 x P80 Condor 20/2 ESCs installed in Bob Blease's "Prinz Eugen"