

## P96 "ServoMorph"

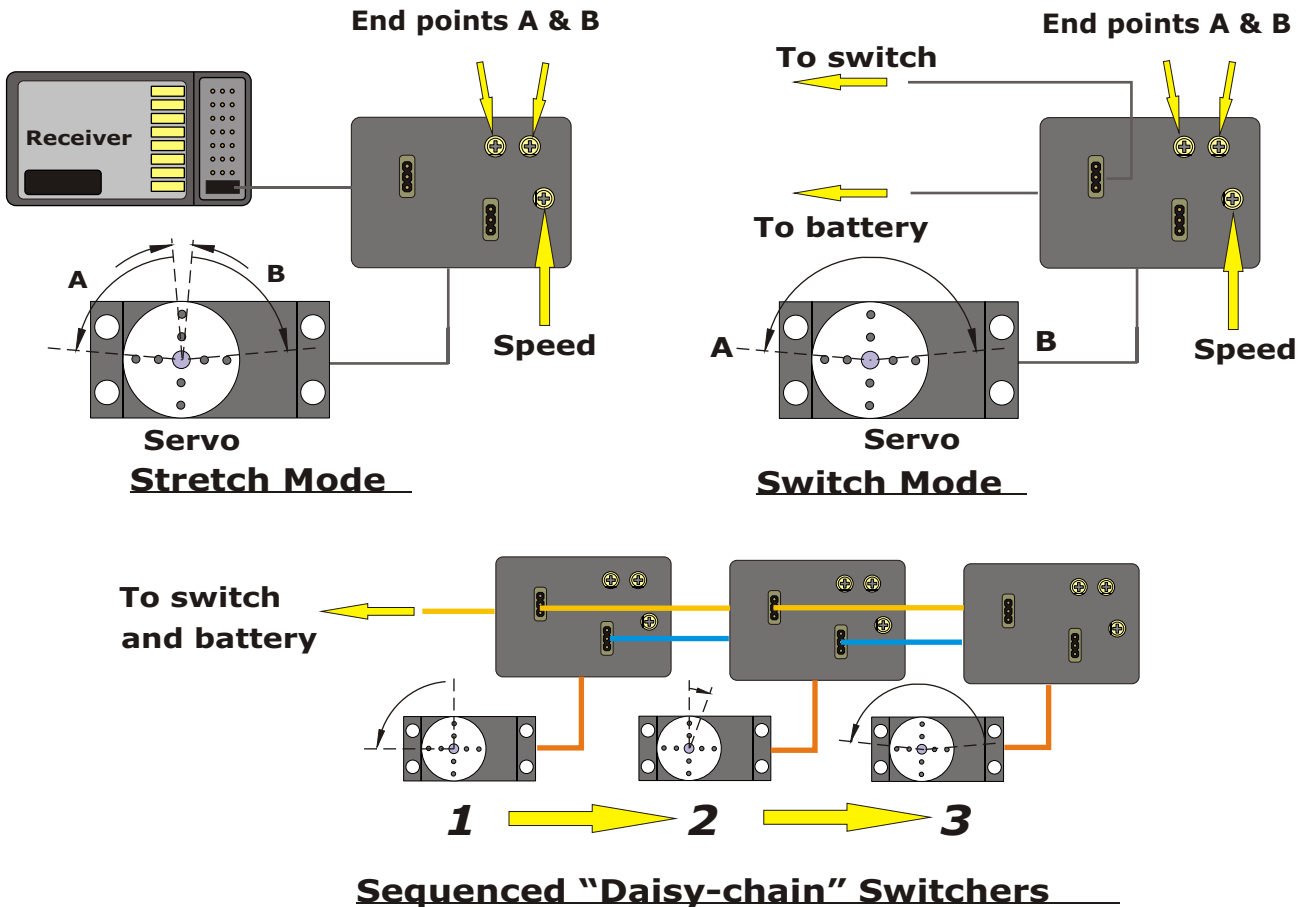

### Stretch/Slow Mode

Connect P96 between the receiver and a servo and you can adjust the travel up to around 160° and the end-to-end speed down to 30 seconds. You can use P96 to reduce the total rotation of a sail-winch, too. We tested a Hitec 785HB and obtained smooth control down to a total of only 1/2 a full turn, using our Hitec Ranger test set. Full movement was approx 3 1/2 turns.

### Switch Mode

Runs the servo from one end to the other just using a simple manual or R/C contact switch.

### "Daisy-Chain"

Couple two or more in series and the switch moves each servo from end-to-end in turn, in sequence. Move the switch back and the whole process happens in reverse. Here you have the perfect driver for cranes, gun turrets, cargo doors and hatches, boat davits - in fact its application can be stretched almost as far as your imagination!

Operates standard digital proportional servos using the usual 4.8v receiver power supply, or 5/6v regulated Battery Eliminator (e.g. P19, P99, P92 or P102).

\*Do NOT use a 5-cell rechargeable pack to power the receiver *directly*; it may fatally damage the unit.

Power *via* a regulated 5v or 6v supply such as a separate BEC or ACTION power board will be fine.

Case size: 53mm x 37mm x 23mm (approx)

P96Y Adaptor/Connector set for Switch Mode is available as an accessory.

**P96**

# “SERVOMORPH”

## Servo Control Unit



P96 is a microprocessor-based device which can be used to change both the speed and the end points of travel when connected to a standard RC servo. In Stretch Mode the unit is connected between the receiver and the servo, and the end-points are adjusted by turning either or both of two small preset potentiometers with a small screwdriver. The speed is adjusted with a third preset. The servo is then controlled by the signal from the transmitter.

In Switcher Mode the unit can be made to run a servo from one end to the other when triggered by a simple switch (the end-points and speed of the servo having first been set in a similar way to Stretch Mode). In addition, two or more P96 units, along with their associated servos, can be connected in series. Having adjusted the travel and speed of the servos as required, the “chain” can then be used to operate a complex sequence of operations, with each servo along the chain moving in turn. This is ideal for such applications as rotating and elevating guns in a turret, operating a crane, lowering boats from moveable davits etc. We have provided for the first P96 in a network to be connected using two small adaptor boards (P96Y). One of these transfers the power from the receiver to the servo chain and the other conducts the signal from the receiver to a single-relay switch (e.g. ACTION P43) to activate the chain by radio control. Note that one of the P96Y units has its signal wire link cut while the other remains intact. Incidentally, if you use our Twin Switch P44 which has two independent relays then you can operate two completely separate chains of servos from one proportional channel. Alternatively you may operate the chain via a micro-switch or single-pole toggle switch. See “Non-RC Operation” diagram.

The unit is supplied ready-built and tested but you will need to cut out the holes in the case lid for the plugs and access to the three pots. File suitable slots along the top edge of the case base to allow the leads to exit the finished case. The cables with plugs are clearly marked with numbered tags which correspond to the diagrams on Pages 1 and 2. Make sure that you fit the plugs the right way round! **DO NOT USE A 5 CELL PACK FOR DIRECT RECEIVER POWER SUPPLY. Power via a separate BEC or ACTION power board is OK.**

In Servo Stretcher mode the position of the servo is controlled by a channel from the receiver. The start and finish points can be set anywhere on the available travel of the servo the P96 will provide up to around 180 degrees of travel with the controls at maximum. The speed of the servo can be adjusted down to a time of 40 seconds end-to-end. Servo Stretcher mode is selected by linking pins 1 & 2 on J2 as shown. In this mode Plug Lead J3 and Header Block J4 are not used. The receiver is connected to Plug Lead J1 while J6 can be used to pass the same signal through to other equipment if required. The servo plugs into fly-lead socket J5.

To set up the P96, you will need to pre-set RV1 and RV2 to give suitable positions for the servo, using the procedure described in this paragraph. Note that the direction of rotation of the servo depends on the relative positions of RV1 and RV2. If RV1 is more clockwise than RV2 the operation will be in one direction; if it is more clockwise then operation will be in the other direction. For initial setup, connect the servo directly to the receiver and use the transmitter to set the servo to the central position (Step 1). If the servo arm or disc is not at its central position when the servo is at neutral, adjust it accordingly. Disconnect the servo from the receiver. Connect the P96 to the receiver and connect the servo to P96, maintaining the neutral position. Set RV1 and RV2 to the middle positions, which corresponds to zero movement, and RV3 to maximum speed (fully clockwise).

Power up the receiver and transmitter. Move the control on the transmitter fully in one direction and adjust R1 until the servo is the required position (Step 2). Move the control fully in the opposite direction and adjust RV2 to move the servo to the other required position (Step 3). Once you are happy with the end-points adjust R3 to set the desired travel speed. To get the smoothest movement, set the speed to minimum and increase it progressively until the servo is just fast enough.

In Switcher mode, the position of the servo is controlled by a switched contact input. Switcher mode is selected by linking pins 2 & 3 on J2. Shorting pins 1 and 2 on either J1 or J6 moves the servo from the start position to the end, and shorting pins 2 and 3 runs it back again. If a change-over contact is used, the Common connects to pin 1 via the white, orange or yellow wire of a conventional 3-wire servo ribbon cable. The Normally Closed connects to pin 3 (black or brown wire) and Normally Open to pin 2 (red wire). Multiple units can be connected in series to give sequenced operation See the diagram on Page 2 "Chain of three x P96 & servos". When the contact is closed, unit one will move first followed by unit two then unit three and so on. When the contact is opened, the sequence is reversed and the last unit will move first with unit one moving last.

To set up each unit first set R3 fully clockwise. With the power off, close the control contact and turn R1 to its centre position. Keep the contact closed, power up the unit and adjust R1 to get the correct position for the servo end-point. Adjust R2 initially to its centre position then open the contact. Re-adjust R2 to get the correct position for the opposite end-point. Once you are happy with these positions adjust R3 to set the travel speed. To get the unit to move in the smoothest fashion set the speed to minimum and increase the speed progressively using R3 until the unit is just fast enough.

When setting up multiple units that will be sequenced, set up each P96 individually before connecting them together. Make sure that there is sufficient space between the servos to allow each to move through its entire travel without the linkage fouling the adjacent servo this is important where you have two or more servos mounted in close proximity.

#### **RECOVERY SERVICE**

A recovery or repairs service ensures that you will not be left with a dead unit for any reason. The Service Charge for this kit is £9.00 including parts (including return shipping cost IN UK).

All returns should include full Credit Card details (Name & Address of cardholder, Card Number, Expiry Date and Card Security Number)

**ACTION R/C ELECTRONICS, 1 Llwyn Bleddyn, Llanllechid, Bangor LL57 3EF, United Kingdom**

#### The small print.....

ACTION R/C Electronics guarantee all products to be free from manufacturing defects for 12 months from date of purchase. This does not cover suitability for specific applications; components worn or damaged by use, tampering or incorrect connection; alteration to original components; damage to batteries or other equipment through use; misuse, or shipping damage. Where goods are found to be faulty, the customer shall return them to ACTION R/C Electronics in their original condition and with their original instructions, packaging etc. Our liability is limited to repairing or replacing goods to their original specification and will not exceed the cost of the goods. By using the product the user accepts all liability. Where a fixed repair charge is applicable, ACTION R/C Electronics shall undertake repairs to the extent that they are judged economically viable. Where such is not the case then the customer will be offered the option of crediting the repair charge towards the cost of a new unit or having the faulty unit returned and the charge refunded (less the cost of return carriage). We reserve the right to modify this guarantee without notice.



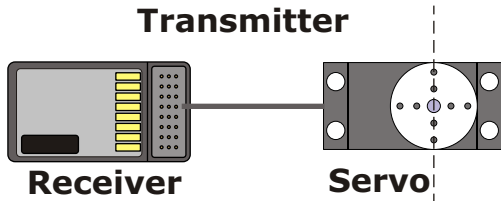
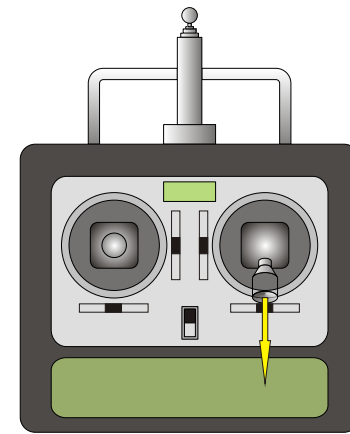
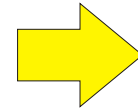
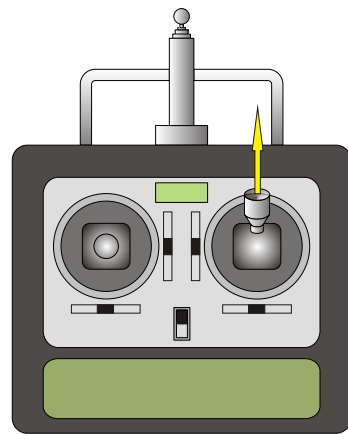
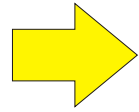
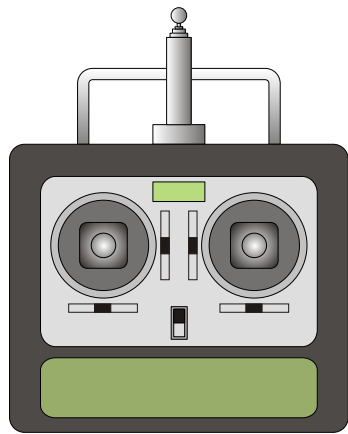

**Step 1**  
Set servo neutral

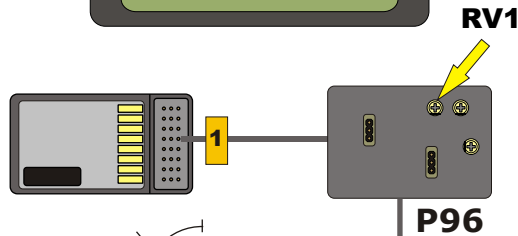

**Step 2**  
Set end-point #1

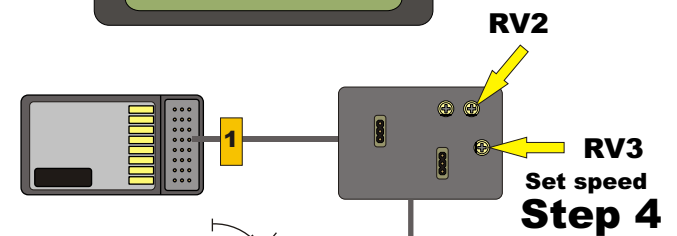

**Step 3**  
Set end-point #2

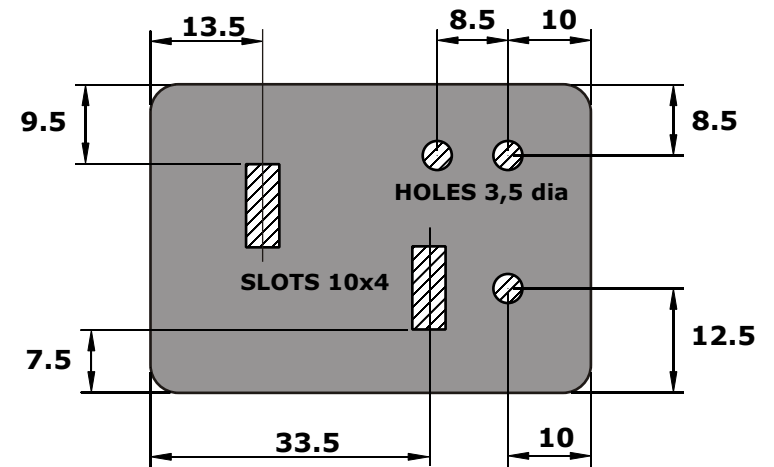
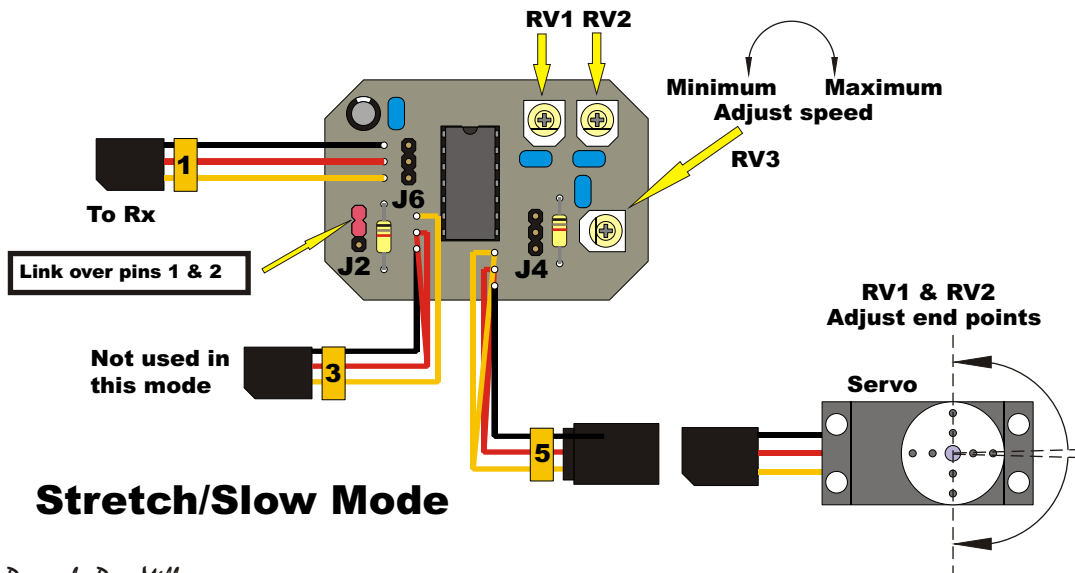

**Cut-outs in case lid**

# P96 Page 2

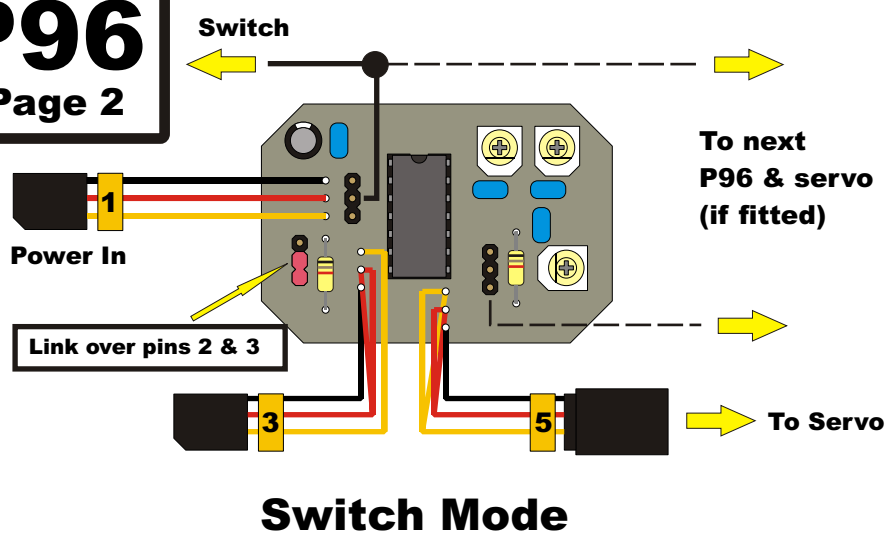

## Non-R/C operation

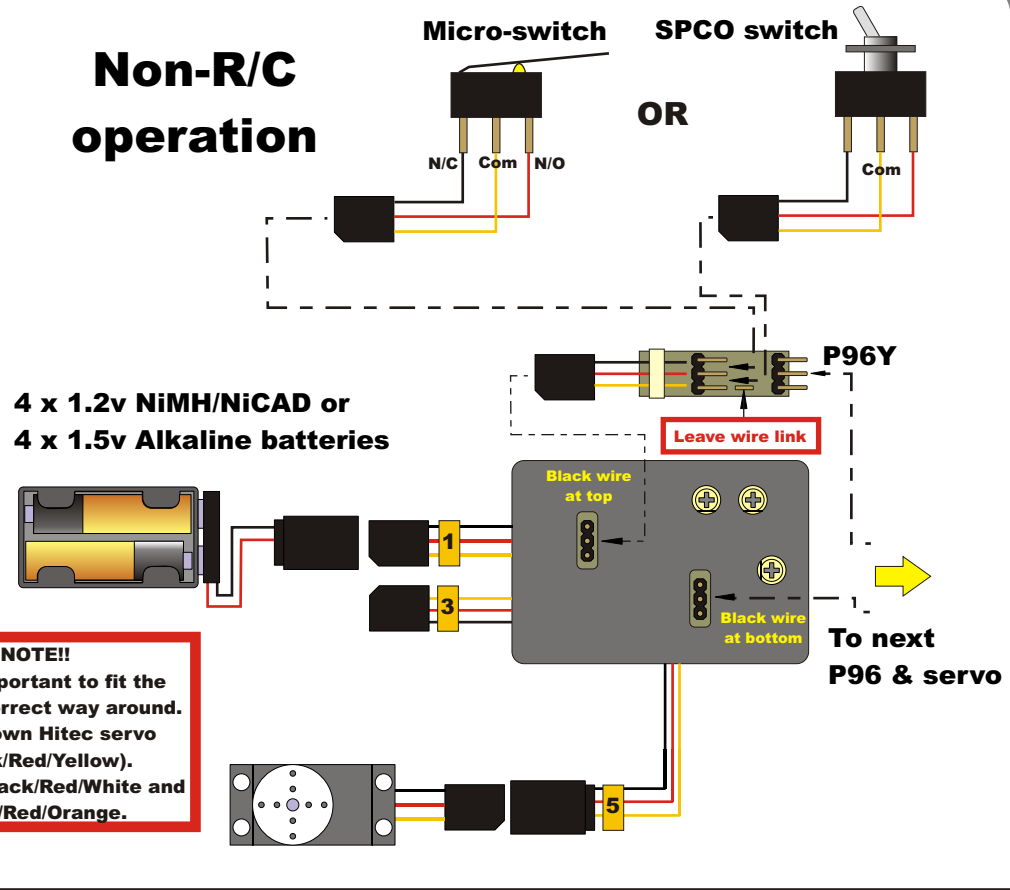

**NOTE!!**  
It is very important to fit the plugs the correct way around. We have shown Hitec servo cable (Black/Red/Yellow). Futaba is Black/Red/White and JR is Brown/Red/Orange.

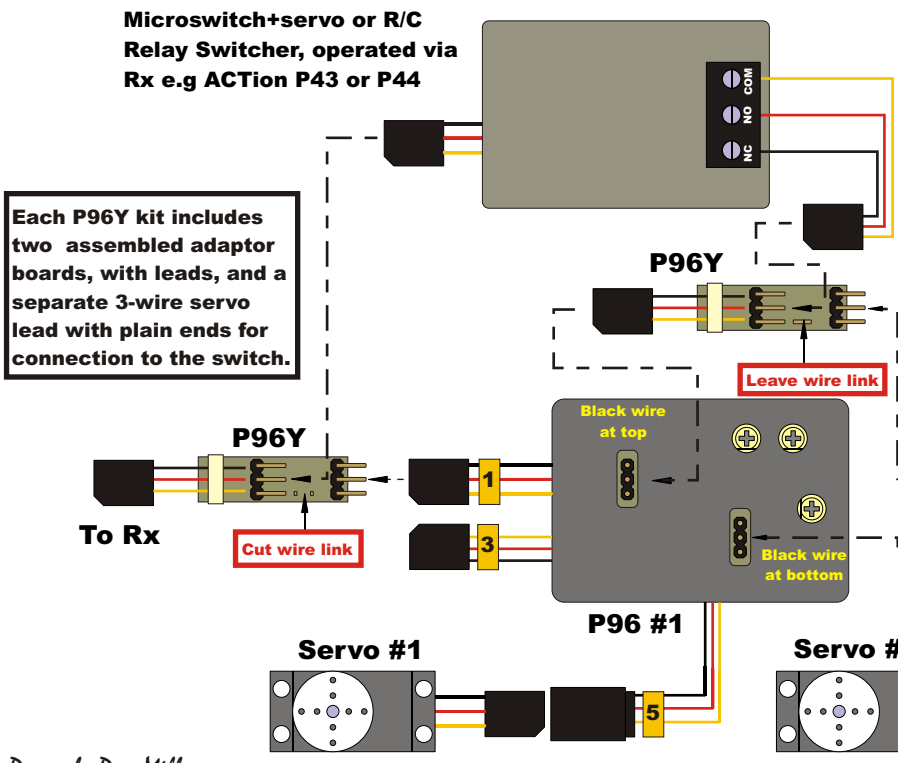

## Chain of three P96 & servos in Switch mode

# Sail Winch operation

with separate high-voltage battery pack for winch

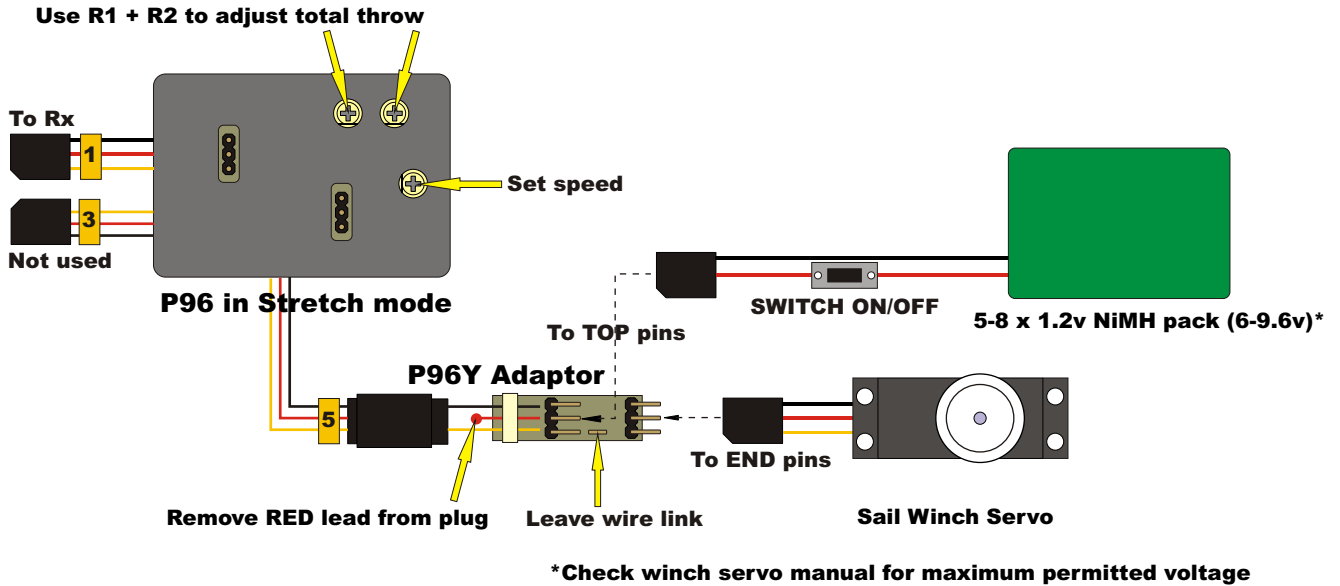

# Sail Winch operation

with high-voltage battery pack for receiver

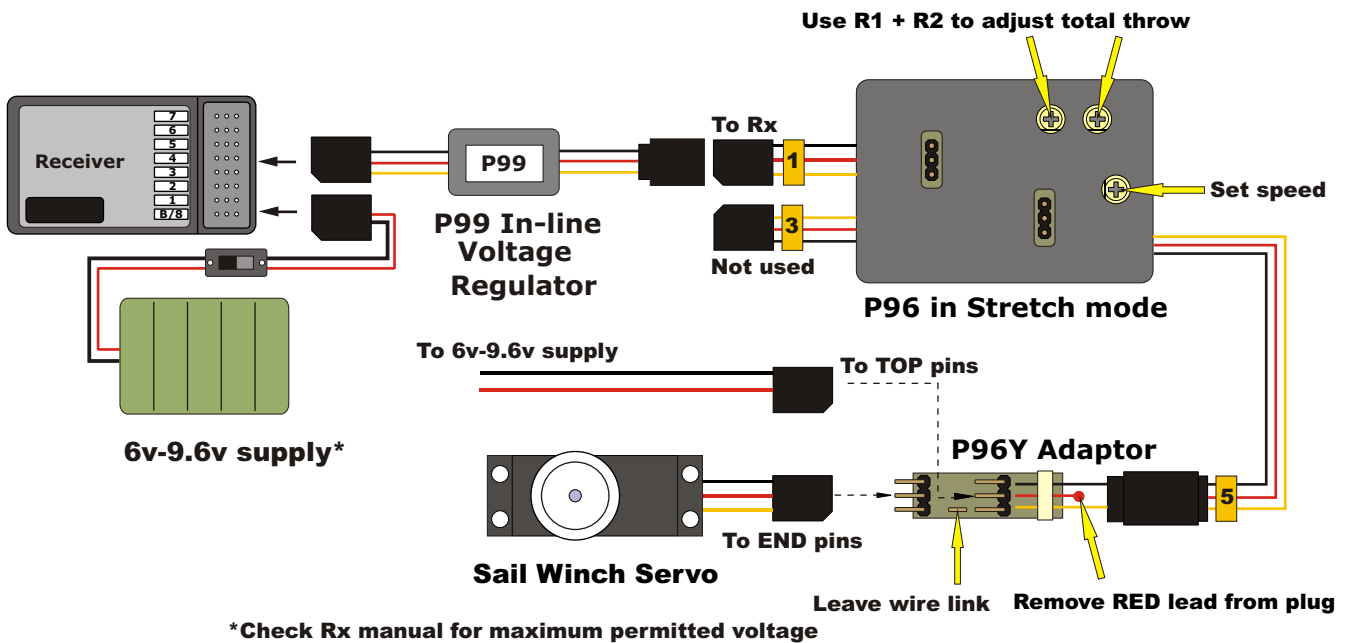

# P96 KIT INSTRUCTIONS

## PCB

The PCB has an insulated (Component Side) and a tinned track side. Components are mounted on the insulated side and soldered on the track side. The PCB for this Project is fully prepared and requires no additional work. Look carefully at the area of the PCB you are working on when soldering to ensure that you do not apply an extra connection with a splash of solder.

## TOOLS

For construction you will require a soldering iron with a fine pointed bit and flux cored solder (22 SWG recommended); a small pair of wire cutters, a screwdriver to make connections and, of course, a good level of light.

## PARTS - DO NOT HANDLE ITEMS IN BLACK CONDUCTIVE FOAM UNTIL INSTRUCTED. (MOS DEVICES)

1/ The short bars with colour bands and a wire at each end are resistors R4 and R5. The coloured bands denote their value, but there should be no problem identifying them in this particular kit as there are only two and they are both 1K. They can be mounted either way around, close to the PCB as drawn.

2/ The tubular electrolytic capacitor C2 is marked with the value 2.2uF and working voltage; it also has a band down one side of the plastic sleeve with a (-) Negative sign on it which signifies which leg goes to the negative. The opposite leg of the capacitor, of course, goes to the positive. Capacitor polarisation (+ and -) is clearly shown on the drawing.

3/ The small blue components with two wires are multi-layer 0.1uF capacitors C1, C3-C5 (marked 104). They can be fitted either way round.

4/ The 3-legged components with a circular slotted top are the preset trimmers R1 R3. They are all the same value and will only fit into the PCB one way around. They should be fitted by inserting the ends of each leg into the PCB and gently rocking the trimmer from side to side while applying downward pressure to push the legs into the holes.

5/ The 14-pin integrated circuit U1 is marked with its type code PIC16F684 ; see the drawing together with the Parts List. It is delivered in conductive foam and should be left in the foam until you are about to fit it. Being a MOS device (Metal Oxide Semiconductor), it can be damaged by static electricity and care must be exercised when handling. It is supplied with a socket. This will enable the builder to solder in the socket during construction, then fit the IC at the end of construction.

6/ The three-pin mouldings with long gold-plated pins one side and shorter extensions the other side are known as headers. The short-pin end goes through the PCB for soldering, leaving the long-pin ends sticking up. These are the pins to which you will fit the link and the connecting plug leads. The link is the tiny moulding (normally red) with a metal strap inside it which shorts out the two pins when fitted. The link is used to select the two different modes of operation (Stretch and Switch).

## CONSTRUCTION

As few parts are used in the construction of the ServoMorph, full construction notes are not needed, just a few pointers. A full pictorial sequence of the build is shown on our website [www.action-electronics.co.uk](http://www.action-electronics.co.uk) if you follow the links to P96 and then click on the small graphic.

I would suggest that you fit the socket for U1 first; it will help to give you your bearings as to what goes where. Note the small notch at one end of the plastic moulding and ensure that it is fitted as shown in the drawing, soldering all pins carefully.

Use pointed, self-locking tweezers to hold the headers in place against the PCB while soldering one pin, then remove the tweezers and solder the other two pins.

Cut the double-ended servo extension lead supplied in half and fit the female (socket) part to holes J5 and the male (plug) part to J3. The extra servo lead (male plug) goes into J1. MAKE SURE YOU FIT THESE WITH THE WIRES THE CORRECT WAY AROUND!! Strip about 6mm of insulation from each wire, twist the strands together and apply a light tinning of solder. Snip the end at about 45° and it should fit into the PCB hole. Trim off surplus as shown in Soldering Tips.

## NOTES ON MOS DEVICE HANDLING. USE A SHEET OF ALUMINIUM, COOKING METAL FOIL WILL DO.

Place it on the work surface. Place the PCB, solder side down on it. Place the black conductive foam on it and then rest your hands on it, holding them there while you read through this part of the instructions. The PCB, any tools, the PIC chip and you are now all at the same potential, i.e. static-neutralised.

**WARNING - DO NOT use the black foam as a packing foam in the finished unit, it is CONDUCTIVE.**

The rear of the board can now be cleaned with something like an old toothbrush and some spirit cleaner. Meths will do but Isopropyl Alcohol is very much better. Then check all over the soldered side of the board for good joints and no solder bridges between tracks or round pads. That's the PCB construction completed.

## CASE

File out narrow sections at the top edge of the case (not the flat part with the screw-holes but the deeper box part) so that the leads can exit the case after the lid has been screwed down. Mark and cut/drill the three holes and two slots in the lid for access to the trimmers, and to fit the plugs of other P96 units if you plan to use the daisy-chain network set-up. Installation is a matter of choice but we suggest self-adhesive Velcro "dots" to hold the box in place in the model. See ACTION lists for price.

**P96  
KIT**

**ACTion**  
R/C ELECTRONICS

**COMPONENT LAYOUT**

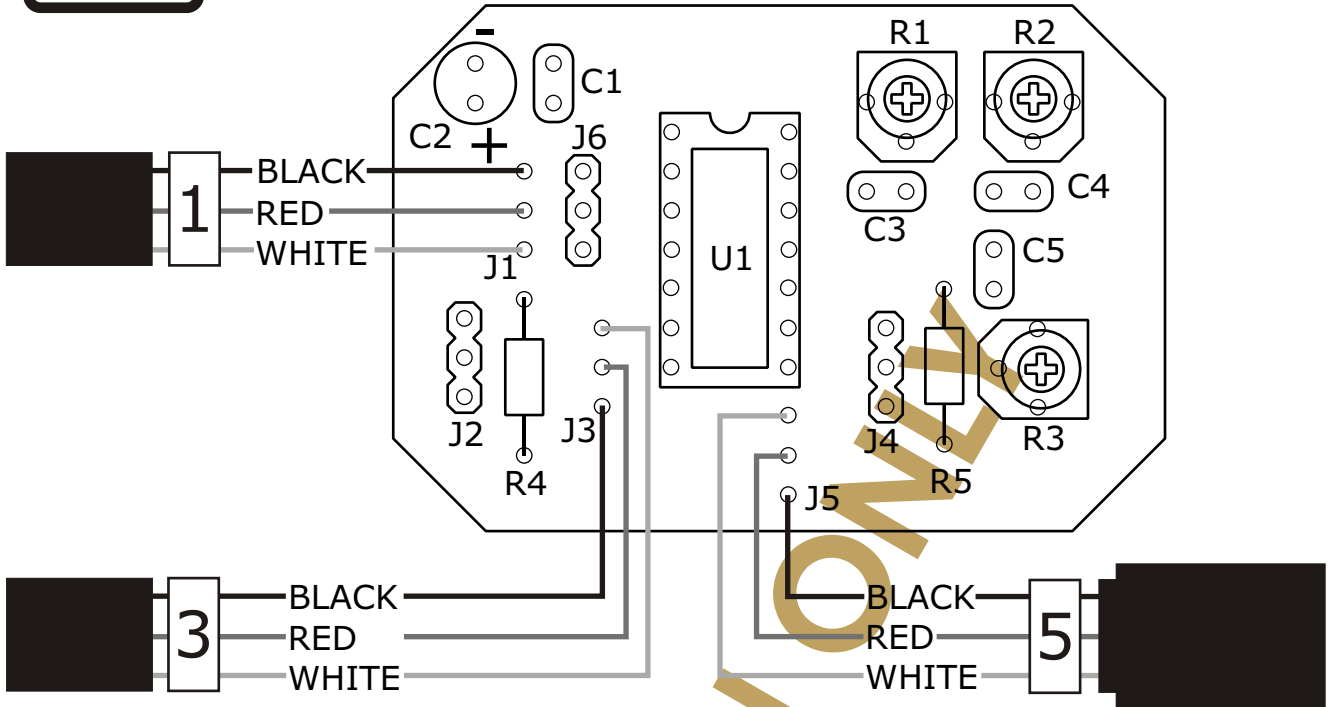

**PARTS LIST**

- J1, J3      Male Lead (plug shell)
- J5          Female Lead (socket shell)
- J2,4,6      3-pin headers
- R1,2,3      10K preset potentiometers
- R4,5        1K 1/4W 5% resistors (BROWN/BLACK/RED)
- C1,3,4,5    0.1uF mono capacitors
- C2          2.2uF Electrolytic capacitor
- U1          PIC16F684 I/C + 14-pin socket
- PCB        P96 ServoMorph
- Case        Rx 2009 with screws and label

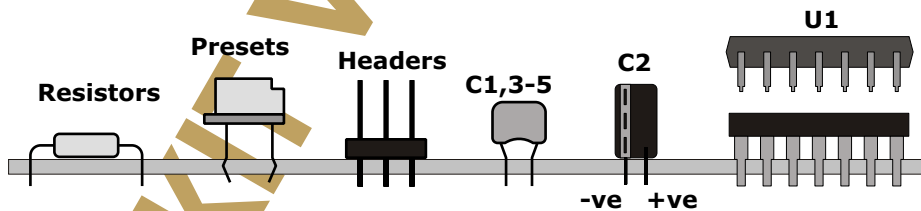

**COMPONENT MOUNTING DETAILS**

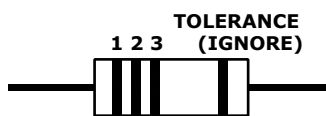

**RESISTOR COLOUR BANDS**

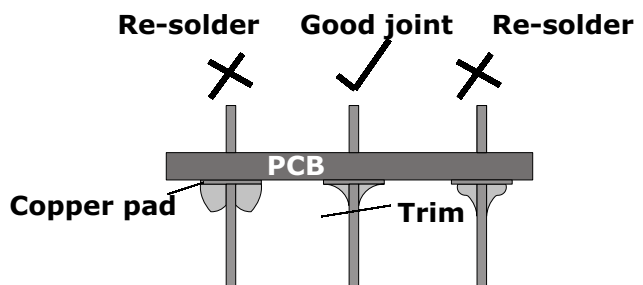

**SOLDERING TIPS**



# P96 SERVOMORPH

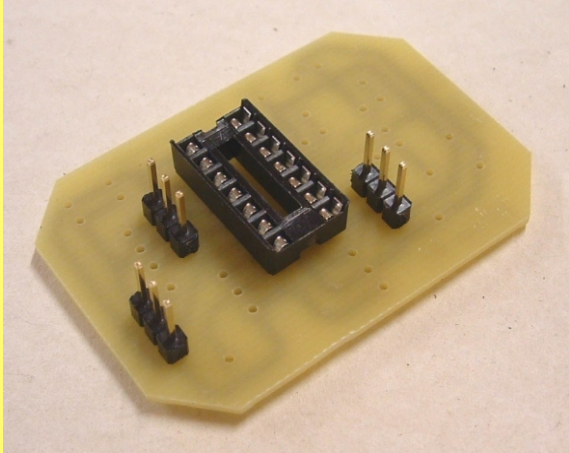

PICTURE 1: PCB with IC socket and headers

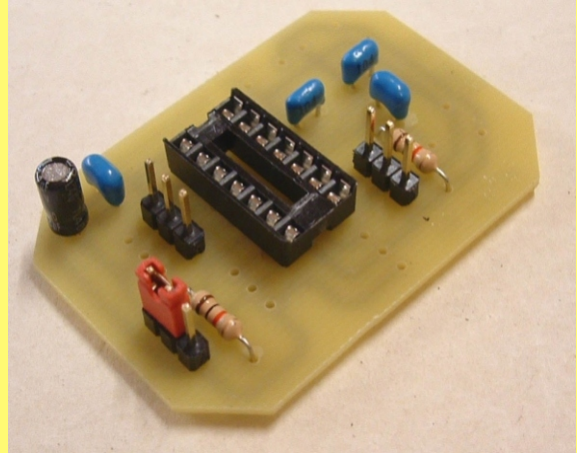

PICTURE 2: Resistors & capacitors added

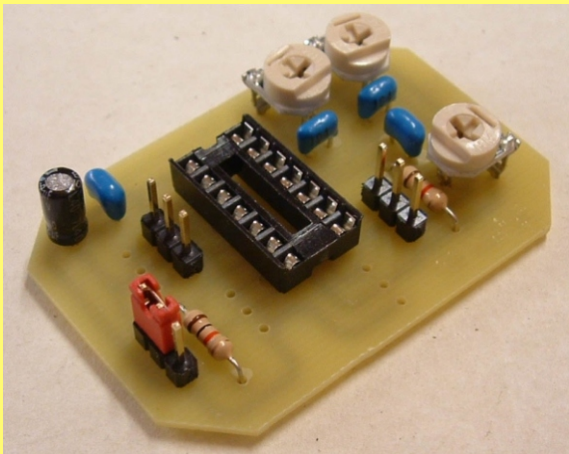

PICTURE 3: Trimmers added

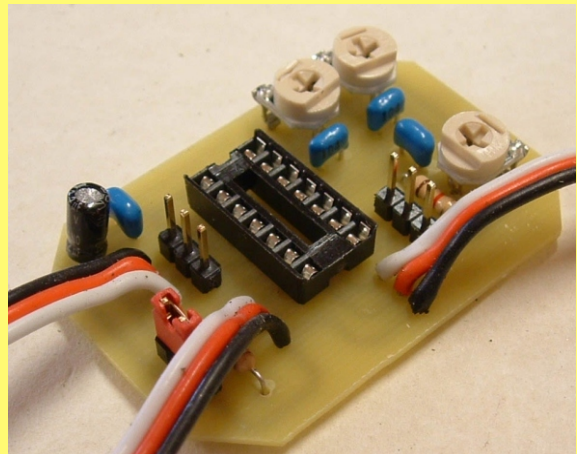

PICTURE 4: Fit three "servo" ribbon leads

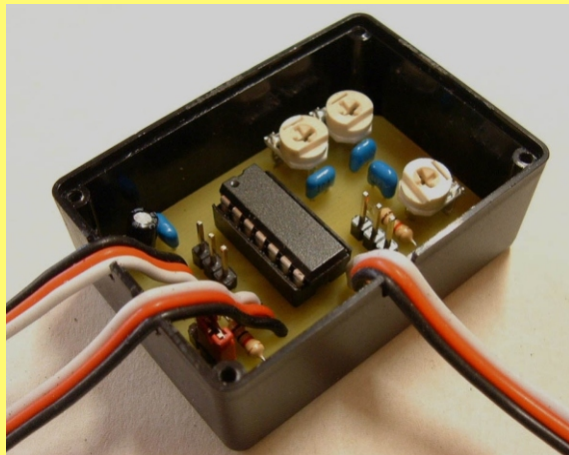

PICTURE 5: Fit PIC chip. NOTE! ANTI-STATIC PRECAUTIONS REQUIRED



PICTURE 6: Mark and cut holes and slots in case lid as per diagram



PICTURE 7: Finished unit