

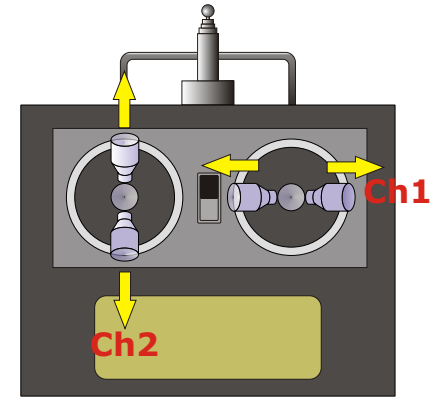

Electronic units shown are available from [www.component-shop.co.uk](http://www.component-shop.co.uk)

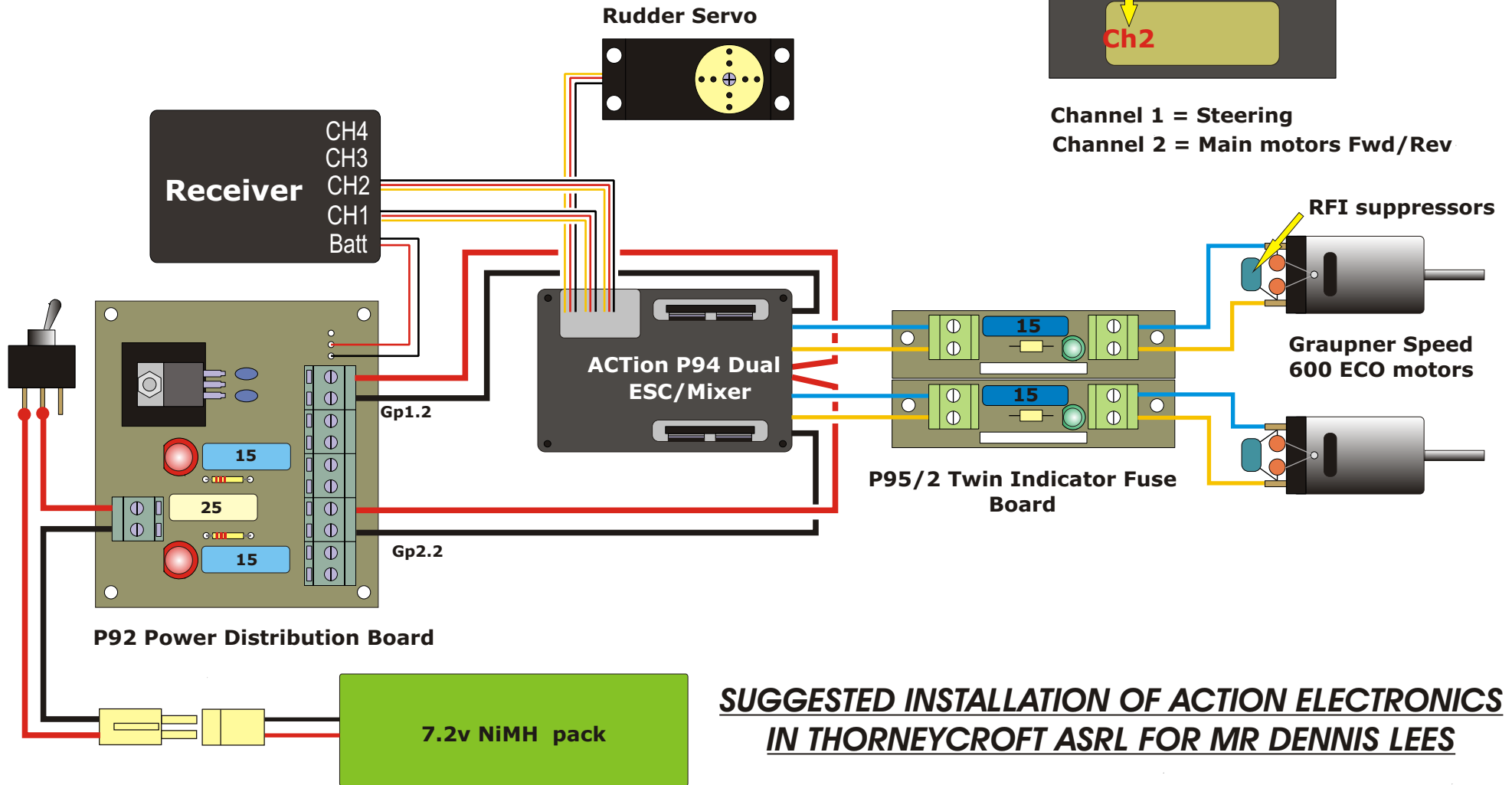

Channel 1 = Steering  
Channel 2 = Main motors Fwd/Rev



**SUGGESTED INSTALLATION OF ACTION ELECTRONICS  
IN THORNEYCROFT ASRL FOR MR DENNIS LEES**

Drawn by Dave Milbourn